

OHIO DEPARTMENT OF TRANSPORTATION

Manual of Bridge Inspection

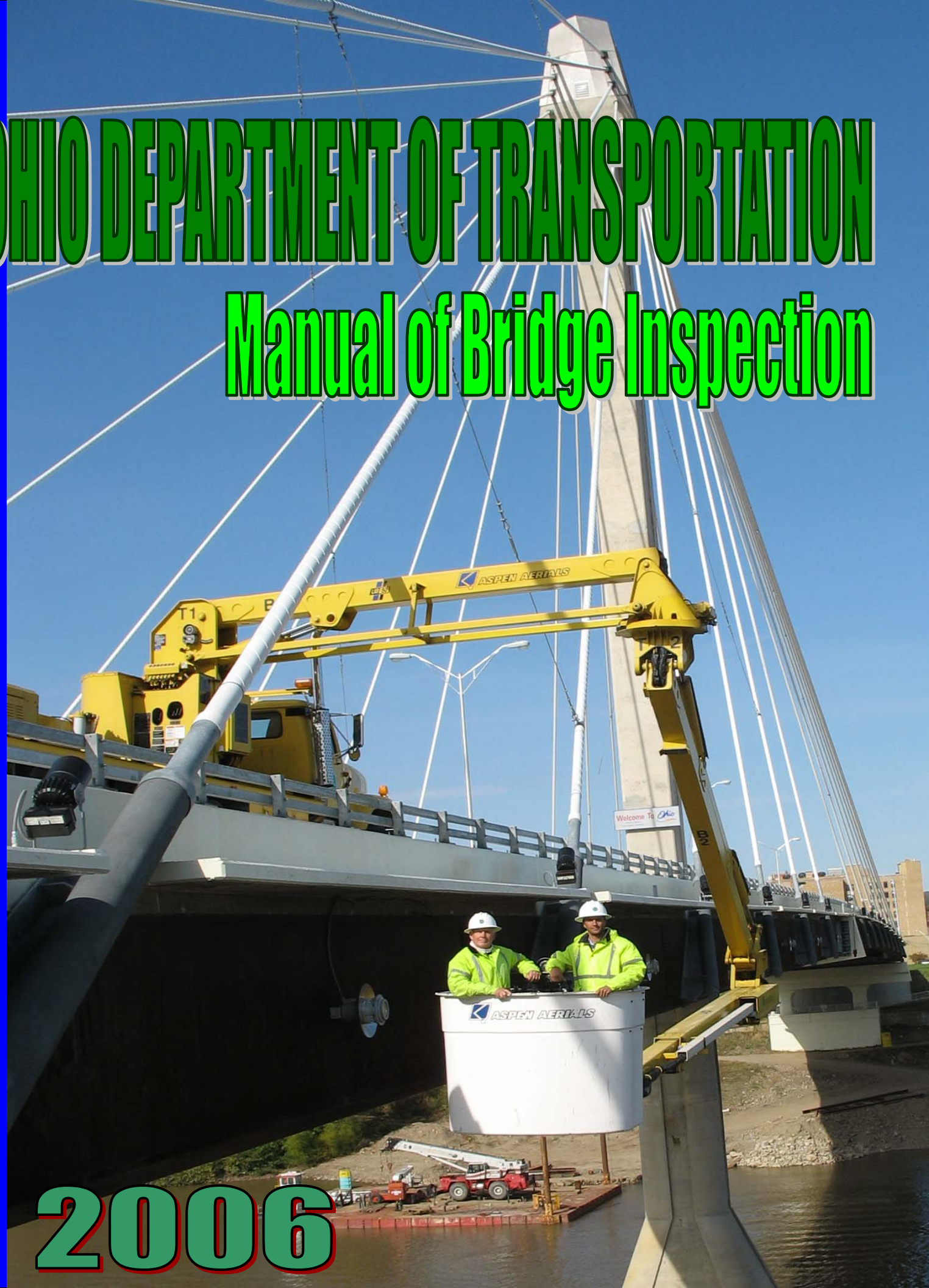

2006

Manual of Bridge Inspection - Index

PART 1 – Bridge Inspection Program Requirements	10
1. Administrative Requirements	10
1.1. Purpose of This Manual	10
1.2. Scope of This Manual	10
1.2.1. Applicable Specifications and Standards.....	11
1.2.2. FHWA Requirements.....	11
1.2.3. Inspection Manuals and References.....	11
1.2.4. Modifications to ODOT Inspection Publications.....	12
1.2.5. General Inspection Program Terminology.....	12
1.2.6. Bridge.....	12
1.2.6.1. Minor Bridge:.....	13
1.2.6.2. Major Bridge:.....	13
1.2.7. Miscellaneous Structures.....	14
1.2.8. Highways.....	14
1.2.9. Public Road Bridges.....	15
1.2.10. Highway Bridges.....	15
1.2.11. Non-Highway Bridges and Structures.....	15
1.2.12. Bridge Categories by Length.....	16
1.2.12.1. NBIS Bridge Length.....	16
1.2.12.2. Ohio Bridges Length (10 ft.–20 ft. Length).....	16
1.2.12.3. Culverts (Length < 10 ft.).....	17
1.3. Responsibilities For Bridge Safety Inspection	19
1.3.1. Bridge Owner Responsibilities.....	19
1.3.2. Department Responsibilities.....	19
1.3.2.1. Highway Bridge Inspection Responsibilities.....	19
1.3.2.2. Highway Bridges-Owner Responsibilities.....	21
1.3.2.3. Highway Bridge Maintenance Responsibilities.....	21
1.3.3. Inspection of Non-Highway Bridges and Miscellaneous Structures over State Routes	21
1.3.4. Department Responsibilities for Non-Highway Bridges over State Routes.....	21
1.3.5. Non-Highway Bridge/Structure Owner’s Responsibilities.....	22
1.3.6. Responsibilities for Railroad Bridges over State Routes.....	23
1.4. Inspection Agreements	24
1.5. Snooper Inspection Program	24
1.5.1. Organization and Operations.....	24
1.5.2. Safety, Maintenance of Traffic, and Access Control.....	25
1.5.3. Snooper Scheduling.....	25
1.6. Removal of structures constituting obstructions or interferences	26
2. Inspection Requirements	28
2.1. General Requirements	28
2.2. Inspection Program Activities	28
2.3. Inspection Program Personnel Qualification	29

2.3.1.	Qualifications for Program Manger for Safety Inspections.....	29
2.3.2.	Qualifications for Reviewer for Safety Inspections.....	30
2.3.3.	Qualifications for Safety Inspections Team Leader.....	30
2.3.4.	Qualifications for Safety Inspections Team Member.....	31
2.4.	Bridge and Structure Inventory and Inspection Records.....	32
2.4.1.	Identification of Bridge Utility Occupancies.....	32
2.5.	Load Rating and Posting.....	32
2.6.	Identification of Bridge Needs and Critical Findings.....	32
2.7.	Inspection Information.....	33
2.7.1.	Identification of Bridge Utility Occupancies.....	33
2.8.	General Types, Scope and Frequency of Bridge Safety Inspections.....	33
2.8.1.	Initial Inspections.....	34
2.8.1.1.	Purpose of Initial Inspections.....	34
2.8.1.2.	Scope and Frequency of Initial Inspections.....	35
2.8.2.	Routine Inspections.....	35
2.8.2.1.	Purpose of Routine Inspections.....	35
2.8.2.2.	Scope and Frequency of Routine Inspections.....	35
2.8.3.	In-Depth Inspections.....	37
2.8.3.1.	Purpose of In-Depth Inspections.....	37
2.8.3.2.	Scope and Frequency of In-Depth Inspections.....	37
2.8.4.	Damage Inspections.....	38
2.8.4.1.	Purpose of Damage Inspections.....	38
2.8.4.2.	Scope and Frequency of Damage Inspections.....	38
2.8.4.3.	Damage Reporting.....	39
2.8.5.	Special Inspections.....	40
2.8.5.1.	Purpose of Special Inspections.....	40
2.8.5.2.	Scope and Frequency of Special Inspections.....	41
2.9.	Combined Sewer System Inspections.....	41
2.10.	Confined space inspection.....	41
2.10.1.	Frequency of bridges with Confined Space.....	42
2.10.2.	Entry Classification.....	42
2.11.	Fatigue and Fracture Inspections.....	45
2.11.1.1.	Fatigue and Fracture Inspection Plan: Purpose of Fatigue and Fracture Inspections 45	
2.11.1.2.	Fatigue and Fracture Inspection Plan: Inventory of Fracture Critical Bridges.....	45
2.11.1.3.	Fatigue and Fracture Inspection Plan: Classification of Fracture Critical Members 46	
2.11.1.3.1.	Load Path Redundancy.....	46
2.11.1.3.2.	Structural Redundancy.....	46
2.11.1.3.3.	Internal Redundancy.....	46
2.11.1.4.	Fatigue and Fracture Inspection Plan: Fatigue.....	46
2.11.1.4.1.	Load-Induced Fatigue Damage.....	47
2.11.1.4.2.	Displacement-Induced Fatigue Damage.....	48
2.11.1.4.3.	Member Defects.....	48
2.11.1.4.4.	Intersecting Welds.....	49
2.11.1.5.	Components of Fatigue and Fracture Inspections.....	50
2.11.1.5.1.	Fatigue and Fracture Inspection Plan: Plan Requirements.....	50
2.11.1.5.2.	Fatigue and Fracture Inspection Plan: BMS Data.....	51

2.11.1.6.	Fatigue and Fracture Inspection Plan; Frequency of Fatigue and Fracture Inspections	51
2.12.	Inspection of Bridges over Water	52
2.12.1.	Assessment for Bridge Scour	52
2.12.2.	Scour Evaluation Using Observed Scour Assessment for Bridges	53
2.12.3.	Scour Analysis Using Theoretical Scour Calculations	55
2.12.4.	Scour Plan of Action for Scour Critical Bridges	56
2.12.4.1.	Scour Plan of Action form definitions	56
2.12.4.2.	Evaluation of Scour Countermeasures	58
2.12.5.	Underwater Inspections	59
2.12.5.1.	Description of Underwater Inspections	59
2.12.5.2.	Maximum Intervals for Underwater Inspections	60
2.12.6.	High Water Inspections	61
2.13.	Inspection of Closed Bridges; General	61
2.13.1.	Inspection of Closed Bridge	62
2.13.2.	Inspection of Closed Bridges during construction	62
2.13.3.	Scope and Frequency of Closed Bridge Inspections	62
2.14.	Railroad Bridge Inspections; General	63
2.14.1.	Railroad Notification	63
2.14.2.	Inspection findings Notification	63
2.15.	Inspections of Non-Highway Bridges and Structures over State Routes: General	63
2.15.1.	General Requirements for Overhead Bridge Safety Inspections	64
2.15.2.	Frequency of Bridge Inspections	65
2.16.	Bridge and Structure Emergencies	65
2.16.1.	Reporting Bridge and Structure Emergencies	65
3.	Bridge Restrictions	65
3.1.	Bridge Restrictions; General	65
3.2.	Bridge Restrictions; Statutes and Regulations	65
3.3.	Bridge Restrictions; Signing	66
3.4.	Bridge Posting Evaluations	67
3.4.1.	Elements of a Bridge Posting Evaluation	67
3.4.2.	Weight Restrictions Based upon the Condition of the Bridge	67
3.4.3.	Bridge Restrictions Types of Weight Postings	68
3.4.4.	Procedures for Posting Restrictions on Department Bridges	68
3.4.5.	Procedure for Rating	69
3.4.6.	Implementation of Posting	70
3.4.7.	Procedure for Rescinding Posting	71
3.4.8.	Procedure for Changing Posting	71
3.4.9.	Required information for Posting, Rescind, Procedure for Rescinding Posting	71
3.5.	Procedures for Posting Restrictions on Locally-Owned Bridges	72
3.5.1.	Posting Approval Authority	73
3.6.	Vertical Clearance Restrictions	73
3.6.1.	Maximum Legal Height of Vehicles	74
4.	Quality Measures for Safety Inspection	74
4.1.	Quality Measures: General	74
4.2.	Quality Control	75
4.3.	Quality Assurance	76
4.3.1.	QAR Review of Office File	76

4.3.2.	QC Review of Field Inspections	78
4.3.3.	QAR of Bridge Maintenance/Rehabilitation/Replacement Needs	78
4.4.	Documentation of Critical Findings	78
4.5.	Qualifications for Personnel Conducting Quality Assurance Reviews	79
4.6.	Recommended Time Frame For Quality Assurance Reviews	80
4.7.	Disputed of Quality Assurance Findings	80
5.	Training and Certification Program	80
5.1.	General	80
5.2.	Bridge Inspection Training Course	80
6.	Inspection Records, Files, and Reports	81
6.1.	Purpose of Inspection Records and Files	81
6.2.	Inspection Organization Unit File	82
6.3.	Individual Structure Inspection File Contents	82
6.3.1.	Record Retention Period	83
6.3.2.	Inventory Information and Field Inspection Records	83
6.3.3.	Load Rating Analysis	84
6.3.4.	Posting Evaluation	84
6.3.5.	Design Related Information	84
6.3.6.	Waterway and Scour-Related Reports	84
6.3.7.	Construction and Maintenance Records	85
6.3.8.	Miscellaneous Documentation	85
6.4.	Consultant Inspection Report Format	86
7.	Safety Inspection Equipment	89
7.1.	General	89
7.2.	Inspection Tools and Equipment	90
7.2.1.	Visual Aids	90
7.2.2.	Inspection	90
7.2.3.	Measuring Devices	91
7.2.4.	Documentation	91
7.2.5.	Safety	91
7.2.6.	Miscellaneous	91
PART II – Bridge Inspection Condition Assessment	92	
Condition Assessment	92	
CODING THE BRIDGE INSPECTION	93	
REPORT FORM (BR-86)	93	
HEADING	93	
DECK	96	
Item 1. Floor	96	
Item 2. Wearing Surface (Protective System)	97	
Item 3. Curbs, Sidewalks, Walkways	98	
Item 4. Median	98	
Item 5. Railing	98	
Item 6. Drainage	98	
Item 7. Expansion Joints	99	
Item 8. Deck Summary	99	
CONCRETE BRIDGE DECK	99	
STEEL BRIDGE DECKS	102	
TIMBER BRIDGE DECKS	103	

SUPERSTRUCTURE	103
Item 9. Alignment.....	104
Item 10. Beams/Girders or Concrete Slabs	104
Item 11. Diaphragms or Cross frames	105
Floor System (Items 12, 13, 14).....	105
Item 12. Joists/Stringers	105
Item 13. Floor Beams.....	105
Item 14. Floor Beam Connections	105
Items 15 - 23.....	106
Item 15. Verticals	106
Item 16. Diagonals.....	106
Item 17. End Posts.....	106
Item 18. Top Chord.....	106
Item 19. Lower Chord	106
Bracing.....	106
Item 20. Lower Lateral Bracing	107
Item 21. Top Lateral Bracing	107
Item 22. Sway Bracing.....	107
Item 23. Portals	107
Item 24. Bearing Devices	107
Item 25. Arch.....	107
Item 26. Arch Columns or Hangers	108
Item 27. Spandrel Walls	108
Item 28. Protective Coating System (PCS)	108
Item 29. Pins, Hangers, Hinges.....	115
Item 30. Fatigue Prone Connections	115
Item 31. Live Load Response.....	116
Item 32. Superstructure Summary.....	117
APPLICABLE TO ALL SUPERSTRUCTURES	118
CONCRETE SUPERSTRUCTURE	118
PRESTRESSED CONCRETE SUPERSTRUCTURE	119
STEEL BEAM SUPERSTRUCTURE	119
STEEL TRUSS SUPERSTRUCTURE	120
TIMBER SUPERSTRUCTURE	121
MASONRY SUPERSTRUCTURE	121
SUBSTRUCTURE	122
Item 33. Abutments.....	122
Item 34. Abutment Seats	123
Item 35. Piers.....	124
Item 36. Pier Seats.....	124
Item 37. Backwall.....	125
Item 38. Wingwalls.....	125
Item 39. Fenders and Dolphins.....	125
Item 40. Scour.....	125
Item 41. Slope Protection	126
Item 42. Substructure Summary	127
REINFORCED CONCRETE SUBSTRUCTURE	127
MASONRY SUBSTRUCTURE	128

CULVERT	129
Item 43. General	129
Item 44. Alignment	129
Item 45. Shape	129
Item 46. Seams	130
Item 47. Headwalls or End Walls	130
Item 50. Culvert Summary	130
Corrugated Metal Culverts	130
Corrugated Metal Pipe Arches	133
Precast Concrete Culverts	136
Cast-in-Place Culverts	137
Stone Culverts	140
CHANNEL	142
Item 51. Alignment	142
Item 52. Protection	142
Item 53. Waterway Adequacy	143
Item 54. Channel Summary	144
APPROACHES	145
Item 55. Pavement	145
Item 56. Approach Slabs	145
Item 57. Guardrail	145
Item 58. Relief Joints	146
Item 59. Embankment	146
Item 60. Approaches Summary	146
GENERAL	147
Item 61. Navigation Lights	147
Item 62. Warning Signs	147
Item 63. Sign Supports	148
Item 64. Utilities	148
Item 65. Vertical Clearance	148
Item 66. General Appraisal and Operational Status	148
Item 67. Inspected By	150
Item 68. Reviewed By	150
Item 69. Survey	150
SUSPENSION BRIDGES	152
Item 68. Main Cables	152
Item 69. Suspenders	153
Item 70. Cable Bands	153
Item 71. Suspender Connections	153
Item 72. Towers	153
Item 73. Tower Saddles	153
Item 74. Bent Posts	153
Item 75. Anchorage	154
Item 77. Summary	154
MOVABLE BRIDGES	154
MISCELLANEOUS ADDITIONAL INFORMATION FOR CODING THE BR-86 FORM	155
APPENDIX ITEMS	156

- Bridge Ownership Matrix156
- Scour Plan of Action156
- Critical Findings Report.....156
- Alternate Entry Form156
- QAR form156
- Bridge inspection report – Form BR-86156
- Bridge inspection report – Form BR-86156

PART 1 – Bridge Inspection Program Requirements

1. Administrative Requirements

1.1. Purpose of This Manual

The purpose of the Bridge Inspection Manual is to compile the policies and procedures of the Ohio Department of Transportation as related to the Bridge Inspection Program to ensure:

1. Public safety on bridges
2. Compliance with Federal and State regulations
3. Accurate and adequate information to manage bridges as a critical infrastructure asset

This manual is intended for use by all persons involved in bridge inspection activities.

1.2. Scope of This Manual

The provisions of this Manual are intended for the inspection and management of bridges and culverts involving public roads in Ohio.

This Manual will provide guidance on the following aspects:

1. Responsibilities of various parties for bridge safety inspections
2. Technical standards and specifications for bridge inspection
3. Administrative requirements to meet State and Federal regulations regarding recording and reporting inspection information

Provisions are not included for bridges used solely for railway, rail-transit, or public utilities that are not related to public highways. For bridges not fully covered herein, the provisions of this Manual may be applied, as augmented with additional inspection and rating criteria where required.

This Manual is not intended to supplant proper training or the exercise of judgment by the Engineer, and states only the minimum requirements necessary to provide for public safety. The Owner or Engineer may require the sophistication of inspection, load rating or the testing of materials to be higher than the minimum requirements.

ODOT has a decentralized Bridge Inspection Program that follows the guidelines and standards established by the Federal Highway Administration (FHWA) and The American Association of State Highway and Transportation Officials (AASHTO). Each District Office manages and administers the inspection of department bridges in its area. ODOT's central office, Office of Structural Engineering is responsible for ensuring that ODOT complies with Federal directives regarding structure inspection and maintenance. This includes making sure that all structures are inspected at the proper intervals and that the state structure files are kept up-to-date and accurate. The Office of Structural Engineering is responsible for the overall supervision of the statewide structure inspection and inventory program, statewide structure load posting program, and statewide training of structure inspectors.

Bridge inspection provides information on each bridge that is needed to complete and update each bridge's inventory/inspection record. This data resides in the Bridge Management System (BMS) that was implemented December, 1985. This system accepts, stores, updates and reports physical and operating characteristics for all public bridges in Ohio.

1.2.1. Applicable Specifications and Standards

This Manual of Bridge Inspection has been prepared in accordance with the provisions of Section 5501.47 of the Revised Code of the State of Ohio (highways, streets, and roads within municipalities, and any other highway, street, or road used for public conveyance) which became effective September 28, 1973, and in compliance with the Code of Federal Regulations, Part 650.307. These State and Federal requirements provide for regular and systematic inspection of bridges on, under or over public highways and streets in the interest of public safety and protection of the public investment in such structures.

These requirements establish the areas of responsibility of various authorities regarding inventory requirements, frequency of inspection, qualifications of inspectors, and recording of inspections. Section 5501.47 of the Revised Code provides for the preparation of this Manual to establish standards and procedures for Inspectors representing the several authorities with the State of Ohio charged with the responsibility of bridge inspection.

1.2.2. FHWA Requirements

The National Bridge Inspection Standards (NBIS) were developed after the 1968 Federal Highway Act became effective and were first published as a notice in the Federal Register, Volume 36, No. 81, Page 7851 on April 27, 1971. The NBIS have been amended several times by the Federal Highway Administration to include new provisions for fracture critical inspections, scour evaluations, and underwater inspections.

The NBIS are, therefore, mandated by Federal Law and are intended to ensure the proper inspection of the nation's bridges more than 20 feet (6.10 m) in length on public roads. The National Bridge Inspection Standards are included in subpart C of Part 650 of Code of Federal Regulations, Title 23 - Highways. A copy of the current NBIS is included in Appendix.

The Federal Highway Administration gives policy guidance and establishes criteria and priorities for matching funds under various programs. In addition, FHWA reviews the results of those programs for compliance with the Standards through its annual compliance review.

1.2.3. Inspection Manuals and References

The following specifications, unless otherwise modified in this Manual, shall govern the safety inspection of bridges listed in the following order of precedence:

- 1) ODOT Bridge Design Manual
- 2) AASHTO Manual for the Condition Evaluation and Load Resistance Factor Rating of Highway Bridges, 2003.

- 3) AASHTO Manual for the Condition Evaluation of Bridges, 2000, 2nd Edition, through 2003 interims.
- 4) AASHTO LRFD Bridge Design Specifications, US Units, 2nd Edition, 1998.
- 5) AASHTO Standard Specifications for Highway Bridges, 17th Edition, 2002.
- 6) FHWA Bridge Inspector's Reference Manual, 2002.
- 7) FHWA Manual of Uniform Traffic Control Devices (MUTCD)

Applicable Policies and Standard Procedures

No.: 516-003(P) **TRAFFIC MANAGEMENT IN WORK ZONES INTERSTATE AND OTHER FREEWAYS**

No.: 220 - 001(P) **QUALITY ASSURANCE REVIEW POLICY**

No.223-003 (SP) **QUALITY ASSURANCE REVIEW STANDARD PROCEDURE**

1.2.4. Modifications to ODOT Inspection Publications

Whenever a user believes that modifications or clarification would improve the present bridge inspection and management practice, the following course of action shall be taken.

The proposal for modification to the inspection manual shall include the section to be modified, proposed language to be used, and a narrative of why the proposed modification need.

Proposal shall be sent to: The Office of Structural Engineering
 1980 West Broad St 3rd Floor
 Columbus OH, 43223

Attn: Bridge Inspection Engineer

1.2.5. General Inspection Program Terminology

Definitions for terminology commonly used in the safety inspection program are as follows.

1.2.6. Bridge

Bridge: Any structure, including supports, of 10 feet or greater clear span, or 10 feet or greater in diameter on, above, or below a highway. The span of all bridges will be measured along the centerline of the highway.

Culvert: (culvert bridge) A type of bridge 10 feet or more in span which conveys water or forms a passageway through an embankment and is designed to support super-imposed loads of earth or other fill material plus a live load. Multiple cell culverts under a fill with a distance of 10 feet or more between extreme ends of openings, measured along the center line of the roadway, including multiple pipes where the clear distance between openings is less than half of the diameter of the smaller opening, will be regarded as a bridge.

Structures less than 10 feet are to reference Ohio Department of Transportation's Culvert Management Manual

1.2.6.1. Minor Bridge:

A minor bridge is any bridge that does not meet the definition of a Major Bridge as listed below. Requirements are for a consulting firm requesting prequalification in Minor Bridge Inspection shall have at least two (2) registered professional engineers on staff that have:

1. Attended ODOT's Bridge Inspection School or an equivalent course in another state
2. Had responsibility for the in-depth inspection and report preparation for two (2) or more
 - a. That meet the above definition.
 - b. Submittal Requirement
 - c. Provide a resume and two (2) examples of in-depth bridge inspection reports for each engineer.

Reports need to be signed by the engineer to be considered. The resumes should include the following information:

1. Number of years of experience in bridge inspection.
2. Training courses attended (including place and year).
3. Experience with various types of non-destructive testing.
4. A representative listing of bridges inspected including:
 - A. County/Route/Straight Line Mileage
 - B. Structure Type.
 - C. Bridge Height.
 - D. Bridge Length.
 - E. Maximum Span Length.
 - F. Owner. (Structural File Number, Ohio bridge)

1.2.6.2. Major Bridge:

A Major Bridge meets one or more of the following criteria:

1. More than 1000 feet in length
2. Single bridge with a deck area of 81,000 square feet (9000 square yards) or greater
3. Twin bridges with a deck area of 135,000 square feet (15,000 square yards) or greater
4. Spans the Ohio River
5. Moveable bridge
6. Continuous/cantilever truss bridge
7. Suspension bridge

Other types of bridges listed below that meet or exceed the Main Span lengths:

Type	Main Span
Cantilever truss	300 feet
Arch, deck & through trusses	250 feet
Concrete deck arch	130 feet
Continuous steel girders	150 feet
Cable Stay	300 feet

Bridges that do not meet this definition are considered minor bridges. The overall bridge length is not considered in the Major Bridge Definition. A consulting firm requesting prequalification in Major Bridge Inspection shall refer to **Consultant Prequalification Requirements and Procedures Manual** for submittal requirements refer to the submittal requirements for Minor Bridge Inspection.

1.2.7. Miscellaneous Structures

Other miscellaneous structures such as sign structures, utility bridges, conveyor belts, pipelines, and traffic signal structures are not considered to be bridges. Provisions solely for inspections of such miscellaneous structures are not included herein.

1.2.8. Highways

Highways: Those highway systems named in Section 5535.01 of the Ohio Revised Code, highways, streets, and roads within municipalities, and any other highway, street, or road used for public conveyance.

A highway is a publicly maintained roadway open to the public for the purposes of motor vehicle traffic. A highway is publicly ordained as such through State statute or local ordinance. The term “public road” may be used interchangeably with the term “highways.” Interpretations of this definition include:

1. The following are considered highways or public roads:
 - All State Routes
 - Local roads and streets on the inventory of routes receiving Liquid Fuels Tax allocations
 - All highways open to public vehicular traffic in State parks, forests, etc., even if public access is seasonal
 - Portions of the Ohio Turnpike system open to public vehicular traffic
2. The following are not considered public roads:
 - Privately-owned driveways open to public vehicular traffic
 - Service roads in State parks, etc. not open to public vehicular traffic
 - Ramps and roadways open to the public but not ordained through statute or local ordinance
 - Routes limited to pedestrians, bicycles, snowmobiles, maintenance vehicles and/or emergency
 - Routes not open to public vehicular traffic

1.2.9. Public Road Bridges

State highways (Ohio Revised Code, Section 5501.47): "The Director of Transportation is responsible for inspection of all bridges on the state highway system inside and outside of municipalities, all bridges connecting Ohio with another state for which the Department of Transportation has inspection authority, and all other bridges or portions of bridges for which responsibility for inspection is by law or agreement assigned to the department." The director will inspect any bridge on a highway, with a designated representative of the owner, where he has reason to believe that the report of inspection does not reflect the condition of such bridge or that the inspection did not accord with the standards contained in the Manual of Bridge Inspection.

County Highways (Ohio Revised Code, Section 5543.20): "The County Engineer will inspect all bridges or portions thereof on the county highway system inside and outside of municipalities, bridges on township roads, and other bridges or portions of bridges for which responsibility for inspection is by law or agreement assigned to the county. If the responsibility for inspection of a bridge is not fixed by law or agreement and the county performs the largest share of maintenance on a bridge, inspection will be made by the County Engineer."

Township Roads (Ohio Revised Code, Section 5543.20): The County Engineer will inspect all bridges or portions thereof on township roads. The Board of Township Trustees is not prohibited from inspecting bridges within a township.

Municipal Roads and Streets (Ohio Revised Code, Section 723.54): The legislative authority of a municipality will designate a municipal official to have responsibility for inspection of all bridges or portions thereof within such municipality, except for bridges on the state highway system and the county highway system." The municipality is not prohibited from inspecting any bridge within its limits.

1.2.10. Highway Bridges

Highway bridges are those that carry highways or public roads.

1.2.11. Non-Highway Bridges and Structures

Non-highway bridges are bridges that are maintained on non-highways for the purpose of carrying motor vehicles (e.g. haul road vehicles, private drives, etc.) and/or non-motor vehicle traffic (e.g. pedestrians, bicycles, snowmobiles, etc.). Non-highway bridges also include:

- 1) Bridges carrying non-publicly owned roads open to motor vehicle traffic
- 2) Bridges that are normally restricted to pedestrian/trail use, but may carry occasional motor vehicles only for maintenance purposes or for emergency access (e.g. fire trucks, ambulances, etc.)
- 3) Bridges that carry railroads over highways

Non-highway structures are highway-related structures (not bridges or culverts) such as retaining walls, noise walls, high mast lighting, etc. and include those that carry facilities (e.g. pipelines, sign structures, etc.) over highways or other features. (Note: Structures such as pipe lines, sign structures,

and conveyor systems, even if located over a highway, are not considered to be bridges because they do not carry moving loads (vehicles or trains).

1.2.12. Bridge Categories by Length

The overall structure Length, as defined by the FHWA Coding Guide and ODOT Bridge Inventory manual is the overall length measured along the centerline of roadway from paving notch to paving notch or back-to-back of backwalls of abutments, if present. Otherwise, the Bridge Length is measured from end-to-end of the bridge deck, but in no case less than the bridge clear span. Bridge measurements for culverts, arches and pipes are taken between the inside faces of walls along the centerline of the roadway regardless of their depth below grade. The determination of a bridge is based upon the clear span opening.

The clear span opening, including any intermediate supports, of 10 feet or greater clear span, or 10 feet or greater in diameter on, above, or below a highway. The span of all bridges will be measured along the centerline of the highway. (See Figure 1 & 2)

If there are multiple culverts or pipes and the clear distance between multiple openings is less than half that of the smaller contiguous opening, the measurement is to be between the inside faces of the exterior culverts or pipes. (See Figure 3)

For pipes and arches where the measurement is to be taken between the inside faces, measure the length at the height of the springline. (See Figure 1 & 2)

If the structure is a highway tunnel, measure the Structural Length of the tunnel along the centerline of the roadway.

When underpinning or facing has been added to the bridge substructure, it should not be considered in the opening length measurement unless it extends the full height of the abutment. MSE walls shall not be considered in the opening length.

1.2.12.1. NBIS Bridge Length

In order to be under the jurisdiction of the NBIS, and part of the NBI, the bridge must be a highway bridge and its bridge opening must be greater than 20 ft, measured along the centerline of roadway. BMS Item #66 Bridge Length must be coded when the bridge meets the minimum opening specified for NBIS bridges.

1.2.12.2. Ohio Bridges Length (10 ft.-20 ft. Length)

Bridges with openings less than the NBIS length are not governed by the NBIS; however there are statutory requirements for their inventory and inspection. Bridges in the 10 ft.-20 ft. range may behave in a similar manner to those meeting the NBIS length definition and can present significant risks to public safety. Moreover, these bridges may represent a large portion of the infrastructure that owners have to maintain.

- Inventory and inspect 10 ft.-20 ft bridges at the same level of scrutiny as NBIS-length bridges.

- Maintain these bridge records in BMS for further analysis and as the base information for asset management.

1.2.12.3. Culverts (Length < 10 ft.)

Minor bridges (or culverts) having a clear span less than 10 ft. in length are covered under the Department's Culvert Management Manual. However, minor non-culvert structures with separate bridge superstructures can be very sensitive to heavy axles and should be load rated for posting and safety.

The Department prefers that minor structures less than 10 feet in length be inventoried elsewhere.

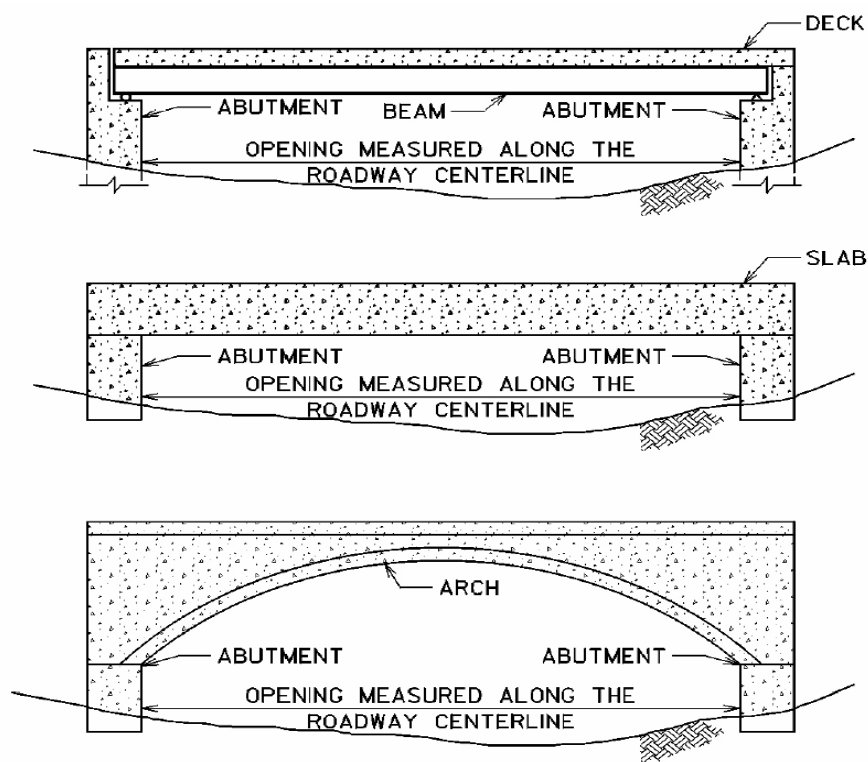

Figure 1- Single Span Bridges

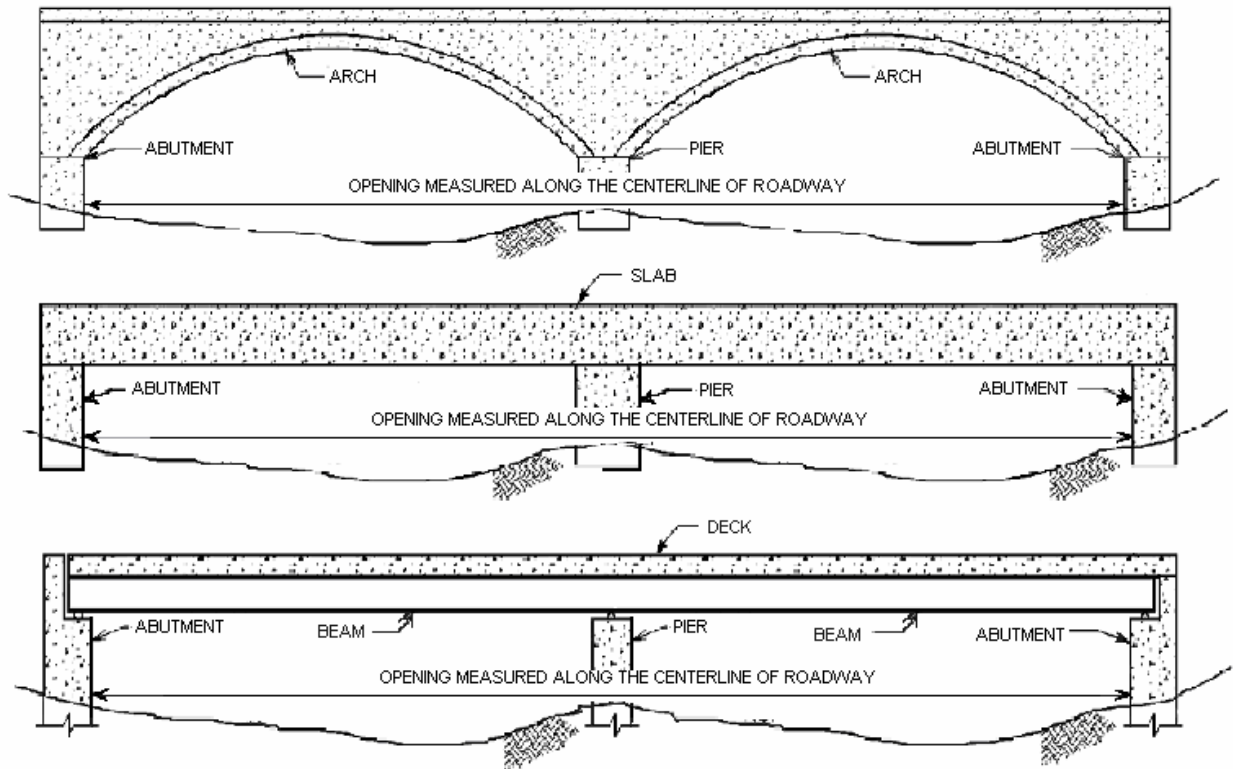

Figure 2- Multiple Span Bridges

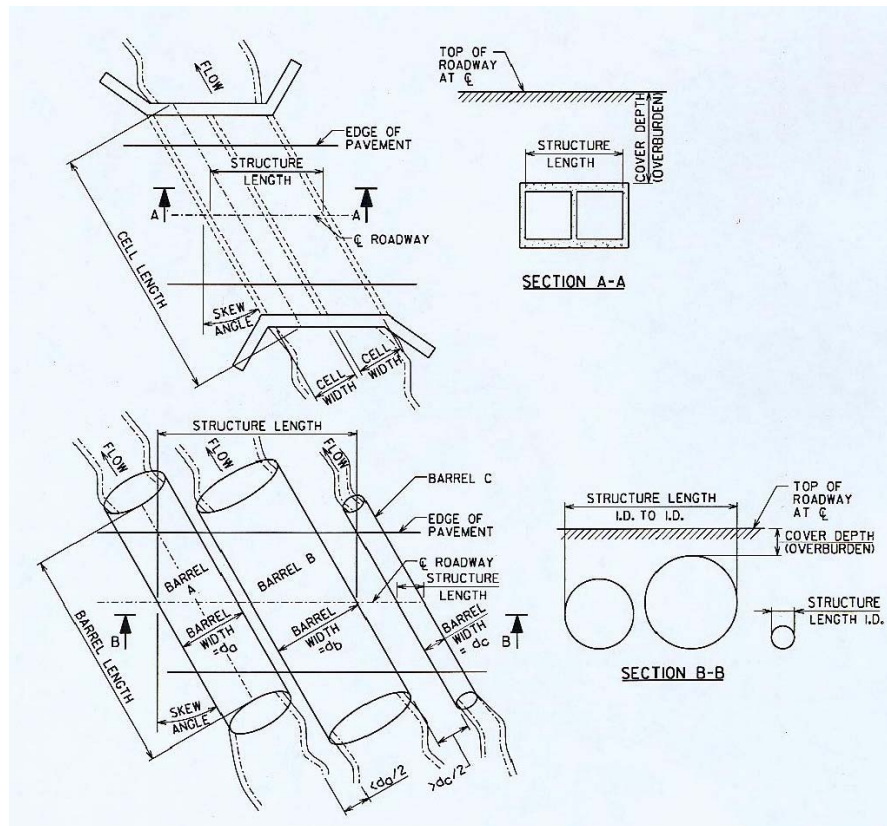

Figure 3- Multiple Span Culvert Bridges

1.3. Responsibilities For Bridge Safety Inspection

For the purposes of this Manual, the term “inspection” encompasses all activities needed to determine and record the required inventory, condition, and appraisal items, including the structural analysis and rating. The term “field inspection” will be used when relating to the investigations at the site only.

1.3.1. Bridge Owner Responsibilities

The Bridge Owner has an overall obligation to ensure that its structure does not present an unacceptable safety risk to the public. In Ohio, the acceptable level of safety is defined by Department standards as presented or referenced in this Manual. Owner must perform restoration or repair activities or take other actions (i.e. closing or removal) to ensure public safety. In order to satisfactorily demonstrate that a structure is safe, safety inspections by the Owner are best practice and, prescribed by law and Department regulations. In this context, the term “Bridge Owner” applies to that party with overall maintenance responsibility for the bridge or structure. Thus, Bridge Owners may include the Department, Counties, Municipalities, Villages, State Organizations, Private, or Federal Agencies. The responsibilities of the Bridge Owner are further delineated for each type of bridge in the following sections.

1.3.2. Department Responsibilities

In addition to its responsibilities as a Bridge Owner for its many bridges and structures, the Department has federal and State statutory responsibilities for the safety and inspections of public road bridges in Ohio owned by others. Some of the more critical of these responsibilities include assurance of NBIS compliance, proper bridge restrictions for vehicle size and weight, administration of federal monies for NBIS inspection and the reporting of NBI bridge data to FHWA. In addition to public road bridges, the safety of non-highway bridges and structures over State Routes is a Department responsibility. The responsibilities of the Department are further delineated for each type of bridge in the following sections

1.3.2.1. Highway Bridge Inspection Responsibilities

For NBIS highway bridges, the owner responsibilities include:

- Inspection of the bridge in accordance with the NBIS and Department standards
- Reporting of bridge inventory and condition information to the Department in accordance with Department standards and in a timely manner
- Installation and maintenance of proper bridge restriction signing for vehicle weight and size, including barricades for closed bridges.
- Maintenance of bridge inventory and inspection records

DEPARTMENT HIGHWAY BRIDGES: The Districts are responsible to perform and manage the safety inspections of the Department bridges in their jurisdiction. The District shall maintain NBIS certified bridge safety inspection teams. The District shall also ensure that these teams are properly equipped and trained. For other highway bridges (10-20' length) on State Routes or owned by the

Department, the Department shall inventory and inspect those bridges in accordance with NBIS and Department standards.

LOCALLY OWNED HIGHWAY BRIDGES: The local bridge Owner is responsible to perform and manage the safety inspections of all bridges in their jurisdiction. The inspection teams may be from their in-house staff or from consultants, but they must meet NBIS qualifications.

TURNPIKE HIGHWAY BRIDGES: The Ohio Turnpike Commission (OTC) is responsible for the inventory and inspection of the NBIS bridges under their jurisdiction. The OTC will maintain the inventory and inspection data in the Department's BMS in a timely manner. The Department of Transportation will provide technical guidance and assistance for all activities related to the inspection program.

ODNR HIGHWAY BRIDGES: The Ohio Department of Natural Resources (ODNR) is responsible for the inventory and inspection of all Bridges in their jurisdiction. The ODNR will maintain the inventory and inspection data in the Department's BMS in a timely manner. The Department of Transportation will provide assistance for all activities related to the inspection program.

OTHER STATE AGENCY HIGHWAY BRIDGES: Other State agencies that own public road bridges are required to inspect their bridges or to contract with another agency to do so. The Ohio Department of Transportation will provide assistance and coordinate all activities related to the inspection program

FEDERAL LAND HIGHWAY BRIDGES: For Federal Land bridges in Ohio, the Eastern Federal Lands The Highway Division of FHWA is responsible for their inspection and NBI reporting.

HIGHWAY BRIDGE OWNERSHIP IN DISPUTE: Where the ownership of a highway bridge on a State Route is in question; the District is to submit information to enable the Office of Chief Counsel to make a determination of the Department's legal position. If the bridge is an NBIS length bridge and other parties are not fulfilling the NBIS responsibilities, the Department shall inspect the bridge through its Districts until the issue is resolved.

HIGHWAY BRIDGES - DEPARTMENT RESPONSIBILITIES

The Department responsibilities include:

Maintain an inventory of highway bridges in Ohio and their condition in BMS, including:

- All NBIS highway bridges including those owned by locals and other agencies
- All other highway bridges (10'-20' length) on State Routes or owned by the Department
- All other highway bridges (10'-20' length) owned by others when requested by the owner
- Ensure compliance with NBIS for all Ohio highway bridges
- Maintain BMS for all bridges with spans of 10' and greater along roadway centerline
- Reporting NBIS-required bridge inventory and inspection information to FHWA
- QC/QA of bridge safety inspection program.

1.3.2.2. Highway Bridges-Owner Responsibilities

The following guidelines are to be used in determining agency responsibilities for bridge operations. A matrix is shown in Appendix. The bridge operations are defined by Jurisdictional Ownership. There are blank lines left in the matrix each organization should fill out the missing types as they pertain to your boundaries.

Jurisdictional Ownership – Agency accountable for replacement or rehabilitation of the bridge. Rehabilitation work may include but is not limited to: Replacement, repairs or strengthening of the structural deck*, superstructure, substructure, drainage features and corrosion control coatings.

It should be noted that any legal agreement made by both parties transferring duties will overwrite this matrix. All agreements should be a part of the bridge file with all involved parties.

*The structural deck shall be considered anything below the first layer of reinforcing steel.

1.3.2.3. Highway Bridge Maintenance Responsibilities

Maintenance Responsibility shall consist of two levels:

Primary – Clearing debris from deck, sweeping, wearing surface repair**, cleaning bridge drainage systems, vegetation control, marking decks for traffic control, spall removal above traffic, minor and emergency repairs to railing and appurtenance, and emergency patching of decks.

Secondary- Duties to keep such bridge open, in repair and free from dangerous defects amounting to a nuisance.

**The Wearing surface shall be considered any part of the deck above the first layer of reinforcing steel.

Perform all deck and wearing surface repairs flush to the existing grade of the surrounding wearing surface resulting in a smooth riding surface. Perform all repairs using materials with physical properties equal to the existing material resulting in a durable repair.

1.3.3. Inspection of Non-Highway Bridges and Miscellaneous Structures over State Routes

Where a non-highway facility (a bike/pedestrian pathway, utilities, sign structure, etc.) over a Public Road, the bridge/structure needs to be inventoried to be in compliance with NBIS. The NBIS does not require a structural safety inspection as it does for highway bridges. The Ohio Revised Code requires inspection to ensure public safety. The road owner may require the bridge owner to perform a structural inspection.

1.3.4. Department Responsibilities for Non-Highway Bridges over State Routes

The Department is to ensure that non-railroad bridges or structures maintained over State Routes do not pose an unacceptable risk to public safety. In order to do so, all such structures must be inventoried and inspected.

The District responsibilities for the inventory and inspection of bridges over State Routes are:

- Inventory of Bridge Information
- Maintain required inventory data in BMS.
- Maintain a permanent file of inventory and inspection information on the bridge.
- Inspection of Bridge Site
- Record highway-related maintenance needs such as: Signing, drainage, pavement, guiderail, etc.
- Observe the overall condition of the bridge. Inform the bridge owner in writing of any deficiencies noted that present safety and/or maintenance problems.
- Maintain a file of information on the bridge.
- Review and Acceptance of Owner's Bridge/Structure Inspection Report
- Ensure that there is in place a legal agreement between the Department and the bridge Owner concerning the requirements for safety inspection (if applicable).
- Provide Quality Control (QC) review of the Bridge Inspection Report.
- Maintain inspection data in BMS. Provide the Bridge Owner with a copy of updated inspection forms.

BRIDGE DEFICIENCIES: Bridge or structure deficiencies are the responsibility of the Owner. When critical deficiencies are found, the District must take a proactive stance to inform the owner of the Department's concerns and to ensure that the owner takes proper action to ensure public safety. The initial contact may be by telephone or in person, but must be immediately followed by a letter, signed by a staff Professional Engineer (preferably the District Engineer or the District Bridge Engineer) informing the Owner of the bridge condition and the Owner's responsibility for public safety. This notification letter may include field views or inspection reports produced by the Department or consultants. A copy of the bridge deficiency notification letter and other supporting documentation shall be placed in the bridge file.

1.3.5. Non-Highway Bridge/Structure Owner's Responsibilities

The Owner is responsible to maintain the bridge or structure in a condition as to not pose a threat to the public safety. The Owner also has an obligation to demonstrate the safety of that structure to the public whose property the structure crosses. Accordingly, the Owner must inventory and inspect the bridge. The Department policy for bridges and structures over State Routes is to assign the following inventory and inspection responsibilities to the Owner of the overhead facility.

1. Inventory
 - a. Maintain permanent file of bridge/structure records.
 - b. Provide one copy of structure plans to the District for their records.
2. Inspection
 - a. Inspect the bridge, load rate if required, and prepare a bridge inspection report.

1.3.6. Responsibilities for Railroad Bridges over State Routes

In addition to the above requirements of the Ohio Revised Code, the Code of Federal Regulations - 23 highways - Part 650 - Sub-part C - National Bridge Inspection Standards state in part that “these standards will apply to all structures defined as bridges located on all public roads” and that “each highway department will include a bridge inspection organization capable of performing inspections, preparing reports, and determining ratings in accordance with the provisions of the AASHTO Manual and The Standards contained herein.”

Railroad Bridges: Railroad bridges over or under highways will also be inspected annually. Section 5501.47 (B)(1)(c) states that the definition of a bridge includes "structures" upon which railroad locomotives or cars may travel. The inspector will inspect only those portions of the structure which would directly affect the traveled roadway underneath. Any problems requiring immediate attention should be relayed in writing to the owner of the bridge with a copy to PUCO.

This policy applies at all railroad bridge crossings over State Routes under regardless of the status of the railroad. This may include operating railroads, former railroad companies no longer operating as a railroad but possessing abandoned railroad facilities, an abandoned railroad owned by any individual or corporation purchased from a former railroad company, or a railroad being subsidized by the Federal Government.

Because of bankruptcy and reorganization of many railroad companies throughout the state, the responsibility for inspection and/or maintenance for many of these railroad structures crossing highways may be in question. Without ongoing surveillance, public safety may be in jeopardy. Where such structures are situated on right-of-way of non-operating railroads, Railroad crossing of formally abolished companies or successor companies is not clear of the crossing. The Department must be proactive to ensure all railroad bridges over State Routes are properly inspected. Railroad bridges over highways, the PUCO would normally assign maintenance responsibilities to the railroad. Because a good maintenance program would normally begin with a review of the infrastructure conditions, bridge inspections should have already been completed for that purpose. In addition, the Federal Railroad Administration (FRA) issued advisory guidelines in 1995 called “Policy on the Safety of Railroad Bridges” that called for the railroads to inspect their bridges annually.

SAFETY INSPECTION

- The Department will perform limited inspection (by its own forces or by consultant) for the portion of structures carrying railroads over State Routes in the roadway right-of-way.
- It is the Department’s opinion that the structure portion of the non-highway bridge should be inspected by the primary user on a regular basis.

The District is to provide copies of its inspection reports to the other parties with maintenance responsibilities at the crossing.

Because the bridge carrying a railroad over the highway is not an NBIS bridge, Federal reimbursement of inspection costs is not available. For non-NBIS structures, all of the inspection costs should be borne by the structure owner or party responsible for maintenance of the structure.

DEPARTMENT RESPONSE TO DANGEROUS BRIDGE CONDITIONS: For those structures carrying railroads over State Designated Highways, should any dangerous conditions (which would jeopardize highway or railroad traffic) be noted, the PUCO shall immediately notify the railroad. If the situation is urgent, the District should take proactive steps to ensure public safety and contact the PUCO as time permits.

1.4. Inspection Agreements

All agencies shall maintain their own inspection agreements. In the event no agreement can be found The Ohio Revised Code shall govern.

1.5. Snooper Inspection Program

The Department maintains two under bridge inspection vehicles (Aspen Aerials) to assist with the inspection and maintenance of Ohio bridges. The main purposes of this program are:

Provide inspectors access to portions of bridges that are difficult to inspect without climbing to achieve complete and accurate hands-on inspections.

Improve inspection safety by providing a secure platform to perform hands free inspections and avoid difficult climbing

Reduce the cost of reaching inaccessible portions of the bridge and avoid the need for temporary scaffolding or platforms.

Provide access for bridge maintenance activities. Provide timely maintenance or repairs and avoid costly scaffolding or rigging. Maintenance activities are limited by the 600 pound bucket capacity.

1.5.1. Organization and Operations

DISTRICT RESPONSIBILITIES: Districts are responsible for identifying and inventorying bridges that require under bridge access; coordinating and scheduling with central office; coordination and funding of flagman or permits to access bridges over railroads, local roads or within municipalities; coordinating and providing traffic control; providing evening storage locations; providing equipment maintenance support as necessary; providing an alternate equipment operator as necessary; providing bridge inspectors.

STATEWIDE COORDINATION: The Office of Structural Engineering is responsible for scheduling, operating, training and maintenance for the under bridge inspection equipment and program.

SNOOPER OPERATORS: Central Office supplies operators from the Bridge Specialist series to staff the snooper truck. Operators can perform the annual inspection if requested by the district.

BRIDGE INSPECTORS: Each District is responsible to provide certified bridge inspector(s) to take the technical lead and responsibility for the inspection.

DISTRICT MECHANICS/OPERATORS: Districts are encouraged to participate in training and daily operations to develop backup operators and mechanics.

BRIDGE MAINTENANCE: Districts are responsible for coordinating the under bridge equipment with central office when it is used for bridge maintenance.

1.5.2. Safety, Maintenance of Traffic, and Access Control

TEMPORARY TRAFFIC CONTROL: Districts are responsible for coordinating and supplying temporary traffic control in accordance with the departments Temporary Traffic Control Manual.

ACCESS CONTROL: Districts are responsible for coordination and funding of flagman or permits to access bridges over railroads, local roads or within municipalities.

SAFETY: Only trained people shall operate the under bridge equipment. A body harness and lanyard shall be worn and connected to the bucket cleat. A safety vest and hard hat shall be worn. Employees shall stand on the floor of the bucket and not sit or climb on the edge of the bucket or use planks, ladders or other devices in the bucket. The boom and bucket load limits specified by the manufacture shall not be exceeded. Where danger of drowning exists wear a US Coast Guard-approved life jacket

1.5.3. Snooper Scheduling

SCHEDULING: The season of operation for the Snoopers is from mid-March to mid-December of each year. This annual schedule avoids severe winter weather that can affect the safety and efficiency of the operation. This scheduled downtime also allows for the necessary annual maintenance inspection and service. The Department tries to maintain one operational snooper at all times for emergencies. A solicitation of statewide under bridge access needs for inspection and maintenance is made in December of each year via E-mail in preparation for the next season's schedule. The Districts are to incorporate local government and consultant bridge inspection needs into their request when it is feasible and reasonable. Districts should also plan key bridge maintenance activities where the use of the under bridge equipment is advantageous. Central Office will combine all district requests into a master schedule and validate the schedule with each district. After district validation, the master schedule will be forwarded to all districts and posted on the Office of Structural Engineering's web site: <http://www.dot.state.oh.us/se/maintenance/snooper>

Snooper use by government agencies.

LOCAL GOVERNMENT USE. Request the use of the departments under bridge inspection equipment through your district's office prior to January 15th of the requested year. All requests must be made by the bridge owner. The Districts are to incorporate local government inspection needs into their requests when it is feasible and reasonable. The department will invoice the local government for the cost of equipment and operators. The local government must provide traffic control, access control and safety equipment as specified above. The local government can request that the district provide the traffic control and access control. The local government must provide certified bridge inspector(s) to take the technical lead and responsibility for the inspection.

Snoopers use by consultant with ODOT contracts

CONSULTANT USE. Request the use of the departments under bridge inspection equipment through your district's office prior to January 15th of the requested year. The Districts are to incorporate consultant inspection needs into their requests when it is feasible and reasonable. Request for Local government bridges inspected by consultant must be processed as specified above in Local Government Use. Consultants must provide traffic control, access control and safety equipment as specified above. Consultants must provide certified bridge inspector(s) to take the technical lead and responsibility for the inspection.

1.6. Removal of structures constituting obstructions or interferences

The Ohio Revised Code section 5515.02 states - All individuals, firms, and corporations using or occupying any part of a road or highway on the state highway system with telegraph or telephone lines, steam, electrical, or industrial railways, oil, gas, water, or other pipes, mains, conduits, or any object or structure, other than by virtue of a franchise or permit granted and in force, shall remove from the bounds of the road or highway, their poles and wires connected therewith, and any tracks, switches, spurs, or oil, gas, water, or other pipes, mains, conduits, or other objects or structures, when in the opinion of the director of transportation they constitute obstructions, or they interfere or may interfere with the contemplated construction, reconstruction, improvement, maintenance, repair, or use by the traveling public of the roads or highways.

All individuals, firms, or corporations so occupying any road or highway on the state highway system, under and by virtue of a franchise or permit granted and in force, shall relocate their properties and all parts thereof within the bounds of the road or highway when in the opinion of the director they constitute obstructions, or they interfere with or may interfere with the contemplated construction, reconstruction, improvement, maintenance, repair, or use of the road or highway. The relocation within the bounds of the road or highway shall be in the manner and to the extent prescribed by the director.

If, in the opinion of the director, such individuals, firms, or corporations have obstructed any road or highway on the state highway system, or if any of their properties are so located that they do or may interfere with the contemplated construction, reconstruction, improvement, maintenance, repair, or use of the road or highway, the director shall notify such individual, firm, or corporation directing the removal of the obstruction or properties, or the relocation of the properties. If the individual, firm, or corporation does not within five days from the service of the notice proceed to remove or relocate the obstruction or properties and complete the removal or relocation within a reasonable time, the director may remove or relocate the same by employing the necessary labor, tools, and equipment. Any notice required under this section shall be made by personal service, certified mail, or express mail.

If, in the director's opinion, the obstruction or properties present an immediate and serious threat to the safety of the traveling public, the director may remove or relocate the obstruction or properties without prior notice

When the director performs a removal or relocation under this section, the costs and expenses shall be paid by the director out of any appropriation of the department of transportation available for the establishment, construction, reconstruction, improvement, maintenance, or repair of highways, and

the amount thereof shall be certified to the attorney general for collection by civil action.

As used in this section, "road" or "highway" has the same meaning as in [section 5501.01](#) of the Revised Code and also includes any part of the right of way.

2. Inspection Requirements

2.1. General Requirements

The Bridge Inspection Program is federally mandated and has been in effect since 1971. The policies of the bridge inspection program are based upon the National Bridge Inspection Standards (NBIS). The requirements of this manual apply to all bridges and structures located on or over public roads in Ohio, as defined in ORC.

Annual inspection for the NBIS requires us to update the state inventory within 90 days. All inspection must be uploaded no later than March 15th for the previous year's inspection.

2.2. Inspection Program Activities

Bridge field inspection and inventory activities by various parties are needed for a successful statewide bridge safety inspection and management program. While specific responsibilities are detailed in the various sections of this Manual, an outline of the bridge inspection activities is as follows:

FHWA

- 1) Annual Report to Congress on the condition of the nation's bridges
- 2) Establishment of criteria for NBI data
- 3) Collection and compilation of NBI data for all states
- 4) Verification of NBIS compliance for all states and local agencies.
- 5) Provision of federal monies for bridge inspection
- 6) Inspection of Federal Lands bridges in Ohio

Central Office, Office of Structural Engineering

- 1) Development of policies and procedures for the bridge inspection and management
- 2) Collection and compilation of all bridge inventory and inspection data for all public roads in Ohio
- 3) Development and analysis of bridge information for statewide planning needs
- 4) Compliance verification and assurance with NBIS
- 5) Reporting of NBI data to FHWA
- 6) Maintenance and operation The state inventory system (BMS)
- 7) Management of Statewide Quality Assurance Reviews (QAR) program for safety inspection
- 8) Maintenance of a Training and Certification program for bridge inspectors
- 9) Coordination of statewide Scour Assessment program
- 10) Operation and maintenance of ODOT's bridge inspection snoopers fleet.
- 11) NBIS compliance for all of the bridges.

District Offices, Various Offices

- 1) NBIS compliance for all of the bridges for their respective jurisdictions
- 2) Maintenance of an adequate and qualified in-house bridge inspection staff
- 3) Quality Control of their bridge inventory and inspection data/reports
- 4) Quality Control of local bridge inspection reports (Districts only)

- 5) Data entry into BMS
- 6) Review and approval of bridge posting recommendation for selected routes
- 7) Forward a copy of the Bridge Inspection Report to all parties having responsibility for the maintenance and ownership, or shares in the responsibility for maintenance.

Bridge Owner

- 1) Inspection and rating of all bridges (by in-house staff or by consultant)
- 2) NBIS compliance
- 3) Development of bridge postings
- 4) Establishment and maintenance of proper bridge postings
- 5) Reporting of BMS data to Districts for input into BMS
- 6) Develop quality assurance methods

2.3. Inspection Program Personnel Qualification.

The department and all other bridge owners shall maintain or contract with an inspection organization. The organization shall meet the NBIS requirements and this manual. Each owner shall maintain a file defining the organization chart and staffing list. The staffing list is to include any required certification (such as PE licensure, inspection certification (including training and experience), confined space, bridge climbing school, CDL, etc.).

The Department maintains a list of inspection personnel who have successfully completed the Department's bridge safety inspection courses and their current certification status. The Department's State Bridge Engineer will make the final determination of an individual inspector's qualifications.

Successful completion of a training course is based upon receiving a passing score on the FHWA Bridge Inspection course, The Departments Bridge Inspection course, or an approved FHWA bridge training course. A participant for the Department's Bridge Inspection training course is required to receive seventy percent (70%) or better as a passing score.

Definition of Bridge inspection experience. Active participation in bridge inspections in accordance with the NBIS, in either a field inspection, supervisory, or management role. A combination of bridge design, bridge maintenance, bridge construction and bridge inspection experience, with the predominant amount in bridge inspection, is acceptable.

2.3.1. Qualifications for Program Manger for Safety Inspections

Inspection program managers make important decisions ranging from suggestions regarding the allocation of scarce rehabilitation dollars to the decision to close a major structure. Therefore, it is important that inspectors and program managers are highly trained and adept individuals who understand the mechanics, behavior trends, and economics of a wide variety of structure types.

The qualification of structure inspection program managers:

1. Must have attended and passed a comprehensive two-week training course such as the FHWA “Safety Inspection of In-Service Bridges” (NHI Course Number 130055), or the ODOT Bridge Inspection Training Level I and Level II.
2. Must be a registered professional engineer in the State of Ohio with appropriate training and experience

Note : the NBIS does allow an alternate for item 2. “Must have a minimum of 10 years experience in bridge safety inspection assignments in a responsible capacity.” However, this is overruled in the State of Ohio by the ORC requiring all bridge inspection reports to be signed by an Ohio Registered Professional Engineer

Counties, municipal corporations, or other bridge owners may contract with Consulting Engineers experienced in this field for inspection services. If such Engineers are retained to make the inspection, the work need not be supervised by the governmental authority providing the inspection is made in conformance with this document, the findings are recorded on approved forms, and the Bridge Inspection Report is turned over to the authority for approval and processing. If the inspection is performed by Consulting Engineers, the firm's name and the name of the reviewer is to appear in the "Reviewed By" blank.

2.3.2. Qualifications for Reviewer for Safety Inspections

Must be a registered Professional Engineer in the State of Ohio with appropriate training and experience. The NBIS alternate for item 2. “Must have a minimum of 10 years experience in bridge safety inspection assignments in a responsible capacity.” is overruled in the State of Ohio by the ORC which requires all inspection reports to be signed by an Ohio Registered Professional Engineer

2.3.3. Qualifications for Safety Inspections Team Leader

The Inspection Team Leader (ITL) is responsible for leading the structure inspection team and planning, preparing, and performing structure inspections. The ITL is ultimately responsible for reviewing the inspection report or form and signing it. The ITL is also responsible for the content of any written inspection report. The ITL shall be familiar with this Manual and preferably have a background in such areas as structural engineering, structure behavior trends, bridge maintenance, and rehabilitation techniques. The ITL is also responsible for the general safety of the work site. Safety items can include obtaining and monitoring any required traffic control, ensuring each Inspection Team Member (ITM) complies with safety procedures, proper use of access equipment, and more. There must be at least one ITL at the structure site at all times during each field inspection.

There are five ways to qualify as an ITL. An ITL must, at a minimum:

1. Have the qualifications specified in section 2.3.1 of this section, or
2. Have five years bridge inspection experience and have successfully completed an FHWA approved comprehensive bridge inspection training course; or
3. Be certified as a Level III or IV Bridge Safety Inspector under the National Society of Professional Engineer's program for National Certification in Engineering Technologies

(NICET) and have successfully completed an FHWA approved comprehensive bridge inspection training course, or

4. Have all of the following:
 - a. A bachelor's degree in Engineering from a College or University accredited by or determined as substantially equivalent by the Accreditation Board for Engineering and Technology;
 - b. Successfully passed the National Council of Examiners for Engineering and Surveying Fundamentals of Engineering examination;
 - c. Two years of bridge inspection experience; and
 - d. Successfully completed an FHWA approved comprehensive bridge inspection training course, or.
5. Have all of the following:
 - a. An associate's degree in engineering or engineering technology from a college or university accredited by or determined to be substantially equivalent by the Accreditation Board for Engineering and Technology;
 - b. Four years of bridge inspection experience; and
 - c. Successfully completed an FHWA approved comprehensive bridge inspection training course.

NOTE: Ohio Department of Transportation Team leaders shall attend the Department's Bridge Climb Course and Confined Space training.

An underwater bridge inspection diver must complete an FHWA approved comprehensive bridge inspection training course or other FHWA approved underwater bridge inspection training course.

People who sign inspection reports without meeting those qualifications, or who sign reports without being at the structure site and participating in the inspection as defined in the AASHTO Manual for Condition Evaluation of Bridges, Section 3.4.3, may be subject to prosecution for forgery or fraud under section 2921.11 of the Revised Code or other applicable state or federal laws.

2.3.4. Qualifications for Safety Inspections Team Member

This individual assists the ITL in the field. It is expected that this person, at a minimum, is familiar with appropriate parts of this Manual and has a competency level sufficient to follow the directives of the ITL. To ensure competency, all Inspection Team Members (ITM) should be encouraged to take the ODOT Bridge Inspection Training Level I and Level II. ITM are essentially apprentices and should have the goal of becoming an ITL. ITL and supervisors should provide appropriate training and guidance to assure the ITM progress toward this goal. ITM do not have the authority to sign inspection forms and should never do so. However, ITM should print their name somewhere on the inspection form to document their participation and experience. They should also keep a log of their experience for future reference.

Inspection Team Members Qualifications

1. Have the competency and ability to carry out the duties assigned by the ITL

2.4. Bridge and Structure Inventory and Inspection Records

Records containing the inventory and condition information for bridges and structures are a vital key to managing these critical assets and assuring public safety. Accordingly, inventory and inspection records are to be prepared and maintained in accordance with NBIS. Owners are to maintain in the BMS accurate and up-to-date information on all bridges.

Update the Structure Inventory & Appraisal (SI&A) data into BMS after repairs, rehabilitations, or modifications of existing bridges. New bridges, enter the SI&A data into the State BMS database inventory. All data shall be entered into the system within 90-days after the completion of the work, for State or Federal agency bridges and within 180-days after the completion of the work for all other bridges. Completion of work shall be considered open to public traffic to include part-width construction.

2.4.1. Identification of Bridge Utility Occupancies

Bridge utility occupancies are to be identified and recorded in the BMS. This information allows the Districts to identify the responsible party when a problem or deficiency is noted on the utility itself or its supports. During Routine Inspections, bridge inspectors do not need to inspect the utility facility, but should note if mounting hardware, utility joints, etc. present a hazard to the public or are detrimental to the bridge condition

2.5. Load Rating and Posting

Each bridge or structure carrying vehicular traffic requiring inspection under this Manual shall be rated to determine its safe load carrying capacity in accordance with Bridge Design Manual Section 900.

If it is determined that the maximum legal load configurations exceeds the load allowed at the Operating Rating level, then the structure shall be posted for load restriction in accordance with ODOT Bridge Design Manual, Section 900, and AASHTO Manual For Condition Evaluation.

All bridges with a general appraisal rating less than a four should be reanalyzed using the current condition of the bridge.

2.6. Identification of Bridge Needs and Critical Findings

One of the functions of the bridge (and structure) inspection program is to identify the needs of bridges for repairs, maintenance, preservation, reconstruction and replacement. Bridge owners need this information to respond to those critical deficiencies warranting immediate attention and for the long-term management of these critical infrastructure assets. The FHWA requires the major improvement needs for NBIS bridges for nation-wide planning.

Identify needed maintenance items (e.g. on-demand repairs, preventative maintenance, preservation, etc.) for each bridge using the standard list of Maintenance Activities on the Inspection Form major improvement needs (e.g. rehabilitation, replacement, etc.) as per the instructions of the BMS Inventory Coding Manual by specifying the Type of Work in BMS and other required minimum data.

Critical Findings is a structural or safety related deficiency that requires immediate follow-up inspection or action. All critical findings shall be reported per section 4.4

2.7. Inspection Information

Owners are to maintain in the BMS accurate and up-to-date load capacity and clearance information for all bridges and structures that carry or cross over State Routes or that are owned by the Department. Program Managers are to keep track the type of inspections performed during the annual inspection cycle.

Annual Inspection Cycle Each bridge will be inspected at least once each calendar year at approximately 12 month intervals with no bridge exceeding 18 months. The report should be reviewed and submitted within 90 days from date of inspection. Under normal circumstances, the inspection should be performed and submitted as close to the 12-month interval as possible, to avoid the possibility of filing two inspections on a bridge in any one calendar year and none in the next year.

2.7.1. Identification of Bridge Utility Occupancies

Bridge utility occupancies are to be identified and recorded in the BMS. This information allows the Districts to identify the responsible party when a problem or deficiency is noted on the utility itself or its supports. During Routine Inspections, bridge inspectors do not need to inspect the utility facility, but should note if mounting hardware, utility joints, etc. present a hazard to the public or are detrimental to the bridge condition.

2.8. General Types, Scope and Frequency of Bridge Safety Inspections

There are five general types of bridge inspections: Initial, Routine, Damage, In-depth, and Special Inspections. The type of inspection is not dependent on the type of structure being inspected, the method of access used, or the inspection procedures followed. The scope, intensity, and frequency of various types of general bridge safety inspections are discussed here to provide a better understanding of the purpose and use of each inspection type and to assist in the development of scope of inspection work for individual inspections.

An inspection event, particularly for large, complex, or deficient structures, often requires that a variety of inspection types be performed, using a variety of methodologies. For example, a fracture critical member will routinely receive an in-depth inspection, while the remainder of the bridge may not. In another example, the underwater inspection of a particular structure may require that specific elements receive in-depth inspections, while other underwater elements may require only routine inspection. The following sections describe each of the five types of inspections, along with the purpose and frequency.

The Department has developed a standard Scope of Work for the Safety Inspection of State bridges to be used as the basis for inspection agreements. This Scope of Work (SOW) is intended to provide the framework to cover the types of bridge inspections and allow the user to define additional special requirements and/or efforts.

Each bridge will be inspected at least once each calendar year with no bridge exceeding an 18 month interval. The report should be reviewed and submitted within 90 days for state agencies and 180 days for local agencies from field inspection date. Under normal circumstances, the inspection should be performed and submitted as close to the 12-month interval as possible.

All inspection must be uploaded into the BMS no later than March 15, for the previous years inspections (ie, 2004 bridge inspection cycle needs to be uploaded into the BMS database by March 15, 2005)

2.8.1. Initial Inspections

An Initial Inspection is the first inspection of a new or existing structure, as it becomes part of the bridge inventory. Additionally, reconstructed structures may also require an Initial Inspection to document modifications of the structure's type, size, or location. The Initial Inspection is to include an analytical determination of load carrying capacity.

2.8.1.1. Purpose of Initial Inspections

The Initial Inspection is to verify the safety of a bridge, in accordance with the NBIS and Department standards, before it is put into service. It also serves to provide required inventory information of the as-built structure type, size, and location for BMS (and the NBI) and to document its structural and functional conditions by:

- Providing all Structure Inventory & Appraisal (SI&A) data required by Federal regulations along with all other data required by Department standards and the local owner.
- Determining baseline structural conditions and eliminate deficiencies recorded under previous structural assessments.
- Clearance envelopes (for features carried and those intersected) and bridge waterway openings are to be documented at this time.
- Identifying maintenance needs, including preventative maintenance activities.
- Noting the existence of elements or members requiring special attention, such as fracture critical members, fatigue-prone details, and underwater members.
- Verify construction/rehabilitation contracts.

Documents, including but not limited to, photographs, drawings (design, as-built and shop drawings), scour analysis, foundation information, hydrologic and hydraulic data are to be inserted into the bridge file. Selected construction records (e.g. pile driving records, field changes, etc.) may also be of great use in the future and should be included. Include maintenance records for existing bridges.

Unexpected problems with a small number of newly constructed bridges have demonstrated that safety inspections may be needed even for new bridges to ascertain their initial and long-term safety. Uncompleted non-bridge maintenance items (e.g. roadway drainage, channel debris, etc.) have caused significant bridge damage in several incidences. The inspection cycle is needed for effective planning and programming of bridge maintenance activities, especially on-demand repairs and preventative maintenance items. In addition, new asset management analysis tools for bridges and other assets require high quality bridge condition and needs data collected at regular intervals to provide good decision-making tools for bridge owners.

In the exchange of bridge owners, a letter notifying the District Office and Central Office, Office of Structural Engineering shall be written by the owner retiring the structure. The letter shall inform all parties of their responsibilities.

2.8.1.2. Scope and Frequency of Initial Inspections

The level of effort required to perform an Initial Inspection will vary according to the structure's type, size, design complexity, and location. An Initial Inspection is to be a close-up, hands-on inspection of all members of the structure to document the baseline conditions. Traffic control and special access equipment may be required.

Initial Inspections are performed for each structure after construction is essentially complete and before the bridge is put into service (or returned to service for bridges that have had a major reconstruction). For Department bridges, data entry into BMS for initial inspections is to be made within ninety (90) days of date bridge is put into service. For local bridges, the one-hundred eighty (180) days for data entry allowed by NBIS is acceptable.

Bridges open to traffic during construction operations are required to be inspected

2.8.2. Routine Inspections

Routine Inspections document the existing physical and functional conditions of the structure. All changes to required inventory items that have occurred since the previous inspection are also to be documented. The written report will include appropriate photographs and recommendations for major improvements, maintenance needs (preservation, preventative maintenance or on-demand repairs), and follow-up inspections. Load capacity analyses are re-evaluated only if changes in structural conditions or pertinent site conditions have occurred since the previous analyses.

2.8.2.1. Purpose of Routine Inspections

A Routine Inspection is to satisfy the requirements of the NBIS and Department standards. Routine Inspections serve to document sufficient field observations/measurements and load ratings needed to:

- Determine the physical and functional condition of the structure.
- Identify changes from the previously recorded conditions.
- Determine the need for establishing or revising a weight restriction on the bridge.
- Determine improvement and maintenance needs.
- Ensure that the structure continues to satisfy present service and safety requirements.
- Identifying and listing existing problems.
- Identifying and listing concerns of future conditions.
- Identify any inventory changes from the previous inspection.

2.8.2.2. Scope and Frequency of Routine Inspections

The level of scrutiny and effort required to perform a Routine Inspection will vary according to the structure's type, size, design complexity, existing conditions, and location.

Generally, every element in a bridge does not require a hands-on inspection during each Routine Inspection to provide an acceptable level of assurance of the bridge's ongoing safety. The difficulty is that the areas not needing close-up scrutiny can not always be absolutely determined until after the entire bridge has been inspected and non-critical areas identified. Accordingly, to provide a reasonable level of confidence in the safety of the bridge, knowledge of the structure and good engineering judgment are necessary when considering those portions that will not receive the close-up scrutiny with each inspection.

The following guidance is offered when determining the level of scrutiny needed for adequate inspection of individual bridges:

Areas/elements that may be more difficult to access but that warrant hands-on inspection in each Routine Inspection, include, but are not limited to:

- Load carrying members in Poor condition.
- Redundancy retrofit systems (e.g. Catcher-beams) for fracture critical details (pin hangers, etc.).
- Critical sections of controlling members on posted bridges.
- Scour critical substructure units.
- End regions of steel girders or beams under deck joint.
- Cantilever portions of concrete piers or bents in Fair or lesser condition.
- Ends of Prestressed concrete beams at continuity diaphragms.
- Other areas determined by the Program manager of the inspection to be potentially critical.
- All bearings

No portion of a bridge should go without an In-depth inspection at least once in every five years. The application of these inspection guideline do not relieve the Engineer in charge of the inspection from the responsibility to perform other In-depth inspection tasks and/or tests needed to ascertain the condition of the bridge and assure its safety.

Routine Inspections are generally conducted from the deck, ground and/or water levels, ladders and from permanent work platforms or walkways, if present. Inspection of underwater members of the substructure is generally limited to observations during periods of low flow and/or probing/sounding for evidence of local scour.

Routine Inspections are regularly scheduled inspections. The interval for Routine Inspections should be reduced from the maximum 12 months when the engineer determines that the bridge conditions have deteriorated to the point where additional scrutiny is warranted to ensure public safety. The District Bridge Engineer must approve the scope of work and interval of all inspections.

INSPECTION DATE AND INSPECTION INTERVAL: For the purpose of monitoring compliance, inspection frequency will be checked by the exact date of inspection. The exact date of inspection is to be recorded on the BR-86 form. This date is used to check for NBIS compliance.

2.8.3. In-Depth Inspections

An In-Depth Inspection is a close-up, hands-on inspection of one or more members and a close visual of all members above or below the water level to identify any deficiency not readily detectable using Routine Inspection procedures. An In-Depth Inspection may be limited to certain elements, span group(s), or structural units of a structure, and need not involve the entire structure. Conversely, In-Depth Inspections may include all elements of a structure. In-Depth Inspections can be conducted alone or as part of a Routine or other type of inspection.

2.8.3.1. Purpose of In-Depth Inspections

In-Depth inspections serve to collect and document data to a sufficient detail needed to ascertain the physical condition of a bridge. This hard-to-obtain data is more difficult to collect than data collected during a Routine Inspection.

In-Depth Inspections should be routinely scheduled for selected bridges based on their size, complexity and/or condition. Large bridges (longer than 500 feet) represent large capital investments and warrant closer scrutiny to ensure that maintenance work is identified and completed in a timely manner. Large bridges tend to be more critical to local and area transportation because of the usual lack of suitable detours. For large or complex bridges, it may be more difficult to provide a complete a snapshot of the bridge conditions when access difficulties limit the scope of Regular Inspections.

2.8.3.2. Scope and Frequency of In-Depth Inspections

The level of effort required to perform an In-Depth Inspection will vary according to the structure's type, size, design complexity, existing conditions, and location. Traffic control and special equipment, such as under-bridge cranes, rigging, or staging may be needed for In-Depth Inspections. Personnel with special skills such as divers and riggers may be required. Non-destructive field tests and/or material tests may be performed to fully ascertain the existence of or the extent of any deficiency. On small bridges, the In-Depth Inspection, if warranted, should include all critical elements of the structure.

For large or complex structures, these inspections may be scheduled separately for defined segments of the bridge or for designated groups of elements, connections or details that can be efficiently addressed by the same or similar inspection techniques. If the latter option is chosen, each defined bridge segment and/or each designated group of elements, connections or details should be clearly identified as a matter of record and should be assigned a frequency for re-inspection. The activities, procedures, and findings of In-Depth Inspections will be completely and carefully documented - to an even greater extent than is necessary for Initial and Routine Inspections. Stated differently, In-Depth Inspection reports will generally be detailed documents unique to each structure that exceed the documentation of standard or routine inspection forms.

A structural analysis for load carrying capacity maybe required with an In-Depth inspection to fully evaluate the effect of the more detailed scrutiny of the structure condition.

An In-Depth Inspection can be scheduled in addition to a Routine Inspection, though generally at a longer interval, or it may be a follow-up to a previous inspection. An In-Depth Inspection that includes all elements of the structure will satisfy the requirements of the NBIS and take the place of the Routine Inspection for that cycle.

In-Depth Inspections do not reduce the level of scrutiny for Routine Inspections. Program mangers shall schedule In-Depth Inspection based upon condition and importance. Major bridges (section 1.2.6.2) shall receive an In-Depth Inspection every five years

2.8.4. Damage Inspections

Damage Inspections are performed following extreme weather-related events, earthquakes, vandalism and vehicular/marine traffic crashes, as directed by the District Bridge Engineer. In many ways, a Damage Inspection is a Special Inspection that is necessitated by an extreme event. When major damage has occurred, the inspectors will need to evaluate fractured or failed members, determine the amount of section loss, take measurements for misalignment of members, and check for any loss of foundation support.

2.8.4.1. Purpose of Damage Inspections

Damage Inspections serve to first determine the nature, severity, and extent of structural damage following extreme weather-related events and vehicular and marine traffic collisions/accidents for use in designing needed repairs. A Damage Inspection is to determine the immediate need to place an emergency restriction on a bridge (e.g. weight restriction or closure) for vehicular traffic. If a bridge is closed to vehicular traffic, the need to close it to pedestrian traffic should also be determined.

The findings of a Damage Inspection may be used to re-coup the costs of inspection and needed repairs or reconstruction from involved parties or other governmental agencies. Accordingly, documentation of the inspection may be critical in these efforts. For Department bridges, the extent of damage and estimated costs of repair should be reported to the District damage coordinator. Photographs, videos and sketches can be extremely helpful. See Section 2.8.4.3 for additional information regarding reporting bridge and structure emergencies.

2.8.4.2. Scope and Frequency of Damage Inspections

The amount of effort expended on this type of inspection will vary significantly depending upon the extent of the damage, the volume of traffic encountered, the location of the damage on the structure, and documentation needs. The scope of a Damage Inspection must be sufficient to determine the need for emergency load restrictions or closure of the bridge to traffic, and to estimate the level of effort necessary to accomplish repairs. The capability to make an on-site determination of the need to establish emergency load restrictions may be necessary.

A Damage Inspection is an unscheduled inspection to assess the structural damage resulting from environmental factors or human actions. Damage Inspections are performed on an as-needed basis.

2.8.4.3. Damage Reporting

Reference: 4.4 Documentation of Critical Findings

FOR State owned structures only

An emergency fund is available from Central Office to fund the emergency repairs to damaged bridges. This new SAC 4SR7 emergency fund will alleviate the districts from having to use District allocations to contract emergency repairs.

What Costs are Eligible for the Program:

1. 100% of the Contract Cost Only, including mobilization, traffic control and a hired consultant for plans, if applicable. In house costs such as plan design, inspection costs or any other labor costs are **not** eligible. This fund is intended to be used for damage to bridges caused by accidents and cannot be used for normal guardrail hits or damage to a bridge as a result of graffiti. Each request for use of the funds will be evaluated against the established guidelines. Unique circumstances will be evaluated on a case by case basis..
2. The program will only cover the above costs if the repairs are completed within 12 months from the accident date. The program manager will have the ability to provide an extension to the 12 month requirement if there are extenuating circumstances.

If a bridge is already planned for replacement or major reconstruction, it is not eligible for this program.

Process to Report Damage:

1. Districts submit a bridge report to Office of Structures. The report should include:
 - Accident Patrol Report
 - Bridge Inspection Report
 - Critical Findings Report
 - Estimate of Damage
 - Pictures
2. Office of Structures will forward the above documentation to the Office of Revenue and Fiscal Reporting..

Ellis Programming:

1. Districts email program manager the following information when they are ready to request approval to fund the project.
 - Bridge Number
 - Location
 - Date of Accident
 - Approximate Sell Date - Quarter and Year (should be within 12 months of accident date)
 - Estimate Amount
2. Program Manager will return email with approval or disapproval for use of the program SAC based on the above criteria.

3. Upon approval by the Program Manager, the districts can enter the project into Ellis. Programming using the Bridge Damage SAC 4SR7. The District must then provide the PID# to Rich and copy Stephanie and Lisa.

If a bridge is damaged during the course of an existing awarded construction project, the cost to repair the damage should not be processed against established state/federal funding. The costs to repair should follow the above process utilizing the SAC 4SR7.

Establishing an Accounts Receivable:

1. The Office of Fiscal Reporting will monitor the projects using the SAC 4SR7 and follow up with the districts upon the project's estimated completion date.
2. When the project is complete, the Districts will gather the cost breakdown and forward to the Office of Revenue and Fiscal Reporting who will initiate a final invoice to the insurance company and/or insured.

The documents needed should include the contract cost and any incurred ODOT costs (plan design, inspection or other labor costs). All costs should be itemized with supporting documents including copies of paid invoices, project labor logs, or if a lump sum bid such as heat straightening a copy of the bid. Each package should include a cover sheet summarizing the costs with a grand total for billing. The costs packages are sent to the program manager, Lisa Jones for billing.

3. The Office of Revenue and Fiscal Reporting will invoice **all** bridge damages.

NOTE:

If the above process is not followed and the district bills for bridge damages or the proper documents are not received, then the district will be required to use their own budget for funding.

Revenue Source Supporting this Program:

1. The revenue collected from property damages, (Ex. guardrails, signs, etc.) is certified to the Attorney General's Office.
2. Any money collected from claimant or insurance companies for these projects.

2.8.5. Special Inspections

Special Inspections are scheduled by the Bridge Owner to examine bridges or portions of bridges with known or suspected deficiencies. Special Inspections tend to focus on specific areas of a bridge where problems were previously reported or to investigate areas where problems are suspected. Special Inspections generally are not comprehensive enough to fulfill NBIS requirements for Routine Inspections. Special Inspections can be structured to fulfill the need for interim inspections between the 12-month routine inspections. Special Inspections are conducted until corrective actions can remove critical deficiencies.

2.8.5.1. Purpose of Special Inspections

Special Inspections are used to monitor particular known or suspected critical deficiencies, fulfill the need for interim inspections (i.e. reduced inspection interval for posted bridges), and to investigate bridge conditions following a natural disaster or manmade emergency.

2.8.5.2. Scope and Frequency of Special Inspections

The level of effort required to perform a Special Inspection will vary according to the structure's type, size, design complexity, existing conditions, and type of deficiency being investigated.

The Program Manager, defines the scope and frequency of the Special Inspections. The qualified Inspector performing a Special Inspection should be carefully instructed regarding the nature of the known deficiency and its functional relationship to satisfactory bridge performance. Guidelines and procedures on what to observe and/or measure must be provided. A timely process to interpret the field results by a Professional Engineer is required.

The determination of an appropriate scope and frequency for a Special Inspection frequency should consider the nature, severity and extent of the known deficiency, as well as age, traffic characteristics, public importance, and maintenance history. Special Inspections are typically at intervals shorter than 12 months

2.9. Combined Sewer System Inspections

Culvert and drainage structures that meet the definition of a bridge will be considered a bridge culvert. Combined sewer systems will be inventoried and inspected. The portion of the combined sewer defined as the bridge shall have an interior visual inspection required every five years. An annual inspection report (BR-86) will be required for each year. Note these structures are typically considered confined space.

Large-span multi-plate culverts, including box culverts, arches, pipe-arches, and circular pipes are relatively flexible soil interaction structures and more susceptible to failure when they lose their original global cross-sectional geometry. The inspection of these multi-plate culverts is to be sufficiently detailed to detect and monitor deformations (e.g., bulging; non-uniformity of the arch soffit, longitudinally or transversely; misalignment of plates; tearing; etc.) that could lead to a partial or complete collapse of the structure. Culverts under shallow earth fill are especially vulnerable to such deformations.

Bridge inspectors will monitor the integrity of the culvert's shape as the primary indicator of any structural distress. The inspection file is to contain sketches indicating the as-built geometry and subsequent measurements to monitor the structure's performance at a minimum of two cross-section locations. Paint marks on the culvert will assist the inspectors in ensuring measurements are taken at consistent locations

2.10. Confined space inspection

NOTE: These are the Department guidelines for the treatment of confined space. Owner may elect to follow the department's guideline. However each agency shall be responsible for its own confined space program.

Entry of some bridge components (hollow piers, steel pier caps, box type superstructures) or culvert type bridges may pose occupational safety concerns with regard to confined spaces. Therefore, entry of these items may include additional challenges with requirements for personal protective equipment and following the protocols of the *Ohio Department of Transportation Confined Space Entry Program, and the Alternate Entry Procedures for bridge inspection.*

Any bridge owner employee or consultant entering a confined space using Alternate Entry Procedures or the Confined Space Entry Procedures must have successfully completed a Confined Space training course.

Depending on their size and configuration, bridge components or culvert may meet the definition of being considered a confined space per OSHA (29CFR1910.46). Therefore, inspection procedures will vary with regard to the safety measures used. Entry Classes have been established for inventory requirements and to detail the entry requirements for the inspector.

The following areas shall be considered confined spaces, but not limited to;

- Hollow piers
- Steel box pier caps
- Arch ribs
- Pit areas
- Box type superstructure
- Culverts, (See chart for list of controlling variables)
- Tunnels

All structures classified as confined space by OSHA (29CFR1910.46) or this manual shall have documentation on entry types, dates, noted changes from last inspection, and atmospheric conditions.

The program manger will be responsible for maintaining a list of structures designated as confined space or components designated as confined space. Bridge files shall include all data of past entries and visual survey conducted by the inspector noting atmospheric conditions and physical hazards.

Culverts as Permit Confined Spaces

Some culverts qualify as Permit Required Confined Spaces because they may contain or have the potential to contain a hazardous atmosphere. Due to their stable nature, culverts generally do not contain physical threats such as the potential to trap or engulf an entrant. When the only hazard is atmospheric, alternate entry procedures may be followed (See chart for list of controlling variables).

2.10.1. Frequency of bridges with Confined Space

No structure with confined space shall go without a visual inspection greater than 72 months. A bridge inspection report will be required on an annual basis. The inspection report shall document the last time the confined space was entered.

2.10.2. Entry Classification

Class A (Non-Entry Inspection)

Class A inspections involve gathering inventory and inspection information without entering the structure. The inspector will examine the structure from the openings, noting as much information as possible from a visual check.

Class A inspections can be performed on any culvert; however consideration should be given to extremely long structures or culverts with multiple bends which prohibit obtaining a good view of the entire barrel. An entry inspection is recommended for those culverts.

If structural or other defects are noticed during the non-entry inspection, further investigation via manned-entry or video inspection may be required.

Class B (Non-Permit Required Entry)

Class B inspections are arms-length inspections performed on bridges/culverts that require no special provisions for confined space issues. An air monitor is required at all times while in the confined space.

Class C (Alternate Entry Permit Required)

Class C entry requires the structure to have no known history of atmospheric or physical hazards. Class C inspections are inspections performed on the structure that require Alternate Entry Procedures to be followed. The inspector should review the bridge file prior to each inspection. Contact the county maintenance forces to inquire about any potential problems or changes that may exist at the site. An air monitor is required at all times while in the confined space.

See Ohio Department of Transportation Confined Space Entry Program, and the Alternate Entry Procedures for bridge inspection for details.

Class D (Permit Required)

Class D structures require the full use and implementation of the *Ohio Department of Transportation Confined Space Entry Program*.

Structures that are fully or partially collapsed or have significant infiltration of backfill material or water pose an additional physical threat and should not be entered. If entry is required, the full requirements of the *Ohio Department of Transportation Confined Space Entry Program* shall be followed.

*Class A (Non-entry Inspection) may be used on any culvert where a good view of the entire barrel may be obtained from the culvert ends.

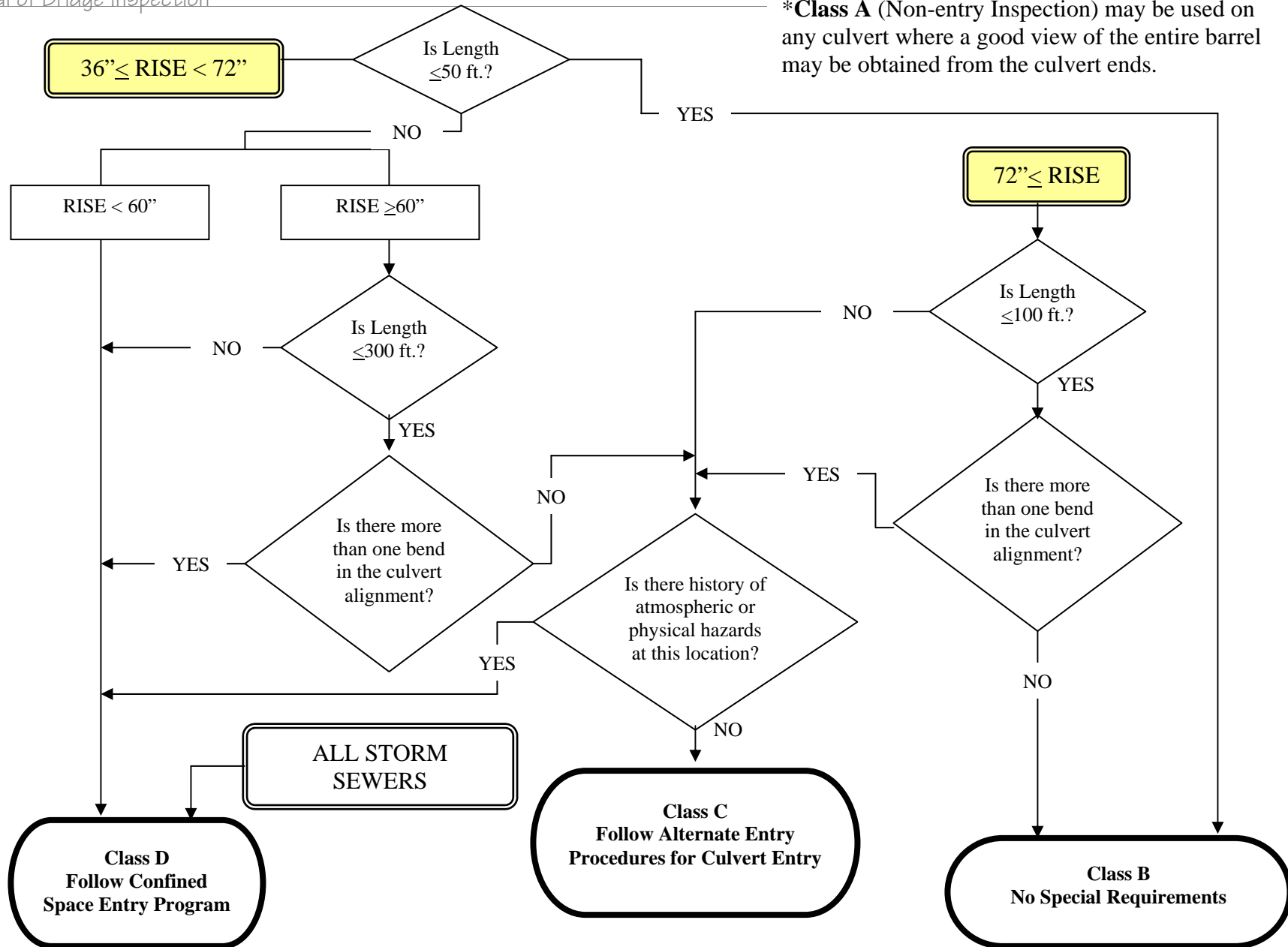

FIG. Culvert Entry Class Flow Chart

2.11. Fatigue and Fracture Inspections

An important aspect of steel bridge inspection is the determination for potential fatigue and/or fracture. Fatigue failure of a material is the initiation and propagation of cracks due to repeated application of loads. Fatigue failures develop at stresses well below the material's yield point stress. Fatigue and fracture can lead to premature and possibly sudden failure of a portion of the bridge or of the entire bridge. In the past, several hundred steel bridges have developed cracks, mostly due to fatigue stress. Although these localized failures have been extensive, only a few U.S. bridges have actually collapsed as a result of steel fractures.

2.11.1.1. Fatigue and Fracture Inspection Plan: Purpose of Fatigue and Fracture Inspections

The purpose of a fatigue and fracture inspection is to identify and record the location of fatigue sensitive details and any problems or potential problems at these locations in order to determine the safety of the structure. For bridges with fatigue-prone details, these inspections provide a history of cracking (time of initiation, rate of growth, etc.) that can greatly assist the engineer in determining the need and priority of repairs and in estimating the remaining life of the bridge. It is essential that fatigue and fracture inspections be performed to identify potential failures before they occur. Fatigue failure of a material is the initiation and propagation of cracks due to repeated application of loads. Fatigue failures develop at stresses well below the material's yield point stress.

When inspecting steel bridges, the inspector must be able to identify a fracture critical member by sight or based on previous reports and drawings. The National Bridge Inspection Standards (NBIS) require that all Fracture Critical Members (FCM's) on a bridge be identified by an engineer, and the inspection procedures listed prior to an inspection.

2.11.1.2. Fatigue and Fracture Inspection Plan: Inventory of Fracture Critical Bridges

The NBIS (§650.303(e)) requires the Program Manager of the bridge inspection organizational unit to:

- Determine and designate on the individual inspection and inventory records those bridges which contain fracture critical members (FCM)
- Maintain a master list of the location and description of such members on the bridge and the inspection frequency and procedures for inspection of such members

The inspection agency is to maintain inventory and inspection information in BMS of all bridges with FCM's, regardless of ownership.

2.11.1.3. Fatigue and Fracture Inspection Plan: Classification of Fracture Critical Members

Fracture is the sudden failure by cracking of a member. A FCM is a steel member in tension, or with a tension element, whose failure would probably cause a portion of or the entire bridge to collapse. Bridges that contain FCM's are deemed fracture critical bridges. Often times fatigue cracks trigger fractures.

Fracture critical bridges may be classified into groups according to the degree of redundancy. There are three types of redundancy related to the basic structural makeup of the bridge. The first type of redundancy, Load Path redundancy, determines whether a bridge is fracture critical or not. Fracture critical bridges have no load path redundancy and if the load path fails, the bridge, or a portion of the bridge will collapse. The other types of redundancy, Structural redundancy and Internal (or Member) redundancy, help to determine the criticality of non-redundant (or fracture critical) structures.

2.11.1.3.1. Load Path Redundancy

A main load-carrying member represents a structure's load path. A bridge with four or more load paths is said to have redundant load paths, and is defined as a redundant structure. Structures with load path redundancy are not fracture critical. A bridge with three load paths requires structural analysis to determine its load path redundancy. A bridge with only one or two load paths is defined as a non-redundant load path structure and is considered fracture critical.

2.11.1.3.2. Structural Redundancy

Bridge structural types that provide continuity of load path from span to span are referred to as structurally redundant. A fracture critical bridge with no structural redundancy is more critical (susceptible to failure) than a fracture critical bridge with structural redundancy. Structural redundancy provides a mechanism to prioritize or rank fracture critical bridges.

2.11.1.3.3. Internal Redundancy

Internal redundancy exists when a bridge member contains several elements bolted or riveted together so that multiple internal load paths are formed. Failure of one member element would not cause total failure of the member. Internal redundancy is also known as member redundancy. A built-up riveted plate girder is an example of a member with internal redundancy. Like structural redundancy, internal redundancy provides a mechanism to prioritize or rank fracture critical bridges. It is not appropriate to apply the concept of internal redundancy to redundant (load path) bridges. Stated differently, do not use internal redundancy to rank non-fracture critical bridges.

2.11.1.4. Fatigue and Fracture Inspection Plan: Fatigue

Fatigue is the tendency of a member to fail at a stress level below its yield stress when subject to cyclical loading. Fatigue cracks generally require large magnitudes of cyclic stresses, corresponding to a high frequency of occurrence or to a long exposure time. Fatigue is the primary cause of failure in fracture critical members.

Three factors that contribute to fatigue in metal are tensile stresses, repetitive loading, and type of detail. It is imperative that a fatigue crack is not left unchecked because it may propagate to a size that would trigger fracture. Fatigue cracks usually provide little evidence of plastic deformation. Hence, they are often difficult to see before serious distress develops in the member.

Structural details have various amounts of resistance to fatigue cracks caused by these large magnitudes of cyclic stresses. The three major parameters affecting fatigue crack propagation life are:

- Stress range
- Number of cycles
- Type of details

Fatigue damage can be categorized as due to either load-induced or displacement-induced stresses. Load induced fatigue damage results from fatigue crack propagation at structural details subjected to the normal in-plane stresses for which they were designed. Displacement-induced fatigue damage is the result of secondary stresses caused by the interaction between longitudinal and transverse members (out-of-plane bending).

2.11.1.4.1. Load-Induced Fatigue Damage

Fatigue Life The number of cycles required to initiate a fatigue crack is the fatigue-crack initiation life. The number of cycles required to propagate a fatigue crack to a critical size is called the fatigue-crack-propagation life. The total fatigue life is the sum of the initiation and propagation lives. Bridge engineers use estimations of total fatigue life in predicting the performance of cracked bridge members.

Fatigue life is greatly influenced by the type of detail used. The details are placed into AASHTO categories shown in the Appendix. Some examples of load-induced fatigue prone details include:

- Groove welded joints flanges and webs
- Ends of welded cover plates
- Welded attachments and welds in tension zones
- Coped connection plates, especially if the cope is flame cut
- Eyebars links and pin/hanger assemblies

The greater susceptibility of these types of details to fatigue damage was recognized by AASHTO by assigning them lower allowable stress ranges in design for a given number of stress cycles.

If the fatigue live load stress remains below the allowable stress range (fatigue limit) for a given detail, then that detail has infinite fatigue life. However, if the stress range exceeds the fatigue limit, the detail has a finite fatigue life and its remaining fatigue life can be determined

2.11.1.4.2. Displacement-Induced Fatigue Damage

This type of fatigue damage is usually associated with relatively small out-of-plane movements. These relative movements, measured as small as hundredths of a millimeter, have been sufficient to cause displacement induced fatigue damage. The following two conditions are required for this type of damage to occur:

- A periodic or cyclic out-of-plane force or displacement.
- An abrupt local change in stiffness where the force/displacement is applied.

Because this damage is caused by cyclic out-of-plane forces in localized areas, cracks can occur in either the primary compression or tension zones of a member. Cracks in a primary tension zone of the member are more critical, especially if their orientation begins to propagate perpendicular to the direction of the primary tension stress, and should be retrofitted. A crack in the primary compression-only zone of a member may not propagate any further once the stiffness constraint has been relieved by the crack.

SMALL WEB GAPS: One common problem of displacement-induced fatigue damage occurs are at small web gaps where high localized stresses are created because the connection is too rigid to allow the displacement to occur. Some examples of small web gaps include; floorbeam-to-girder connections, stringer-to-floorbeam connections, lateral connections to girder or floorbeam webs, diaphragm connections to girder or stringer webs. For welded connections, small web gaps are defined as gaps that are less than the greater of 4 to 6 times the web plate thickness or two inches. For bolted connections, due to the additional stiffness of connection angles or other connection shapes, the web gap is defined as gaps that are less than the greater of 4 to 6 times the web plate thickness or four inches (4”).

2.11.1.4.3. Member Defects

Member fabrication defects such as notches, gouges, and nicks that occur in tension or reversal zones can lead to fracture because they create areas of unintended stress concentration. These defects may be the result of damage during fabrication, erection, rehabilitation, or due to collisions while in service. Fracture can initiate at or adjacent to these defects particularly if the orientation of these defects is perpendicular to the direction of the tension stress. Welding also introduces defects into a member. Welds need to be examined for cracks within the weld metal, at the toe of the weld and in the base metal adjacent to the weld toe. Closely examine poor quality welds since fatigue damage is more likely to begin there. It was common practice to use tack welds on built-up riveted members fabricated from 1945 through 1960. Of particular concern are truss bridges with tack welds used at lacing bars, tie plates, and batten plates on tension

members. A riveted or bolted built-up member no longer has internal redundancy if tack welds are present between the elements that make up the member. Tack welds provide a path for the crack to propagate from one of the member's elements to another.

Members that have misplaced holes filled with plug welds on fracture critical members should receive hands-on visual inspections. Past practice was to fill these holes with weld metal (plug weld) rather than leaving them open or installing bolts. Note if the weld metal is not ground smooth or of poor quality otherwise. Of particular concern are tension members on truss bridges. Bridge inspectors are to carefully examine plug weld locations, looking for breaks in the paint and the formation of oxide powder or rust stains. If weld filled or plug welded holes are encountered in tension areas of the following:

- Girder / Stringer / Floorbeam
- Portion of Web Susceptible to
 - Displacement-Induced
 - Fatigue Damage
 - Lateral Angle
 - Out of Plane Force

For fracture critical members, the weld metal should be tested using non-destructive testing (NDT). A retrofit for this problem would be removal of the weld metal and reaming the hole for the installation of a high strength bolt. The bolt should be tightened to prevent crevice corrosion caused by the accumulation of water or debris.

2.11.1.4.4. Intersecting Welds

Intersecting welds on some bridge details in tension or reversal zones have led to brittle fracture and failure of main longitudinal bridge members without warning. Intersecting welds are defined as welds that run through each other, overlap, touch, or have a gap between their toes of less than 1/8 inch. The intersecting welds of the web-splice-to-flange or flange-splice-to-web are not of concern here. Three-dimensional details with intersecting welds are the critical intersecting welds. These types of details introduce an out of plane force at the intersecting weld.

Examples of some details that may have critical intersecting welds include:

1. Wind bracing connections to girder webs.
2. Floorbeam connections to girder webs.
3. Beams/stringers connections to steel pier caps.

More often than not, the bridge design and shop drawings will not indicate that intersecting welds are present on a bridge. However, excessive welding during fabrication or repairs have resulted in intersecting welds. Because these welds have caused girder failures on redundant, as well as, fracture critical girders, inspectors should examine steel bridges carefully for their presence.

The initial inspection should include a hands-on inspection of all intersecting weld details in tension or stress reversal zones, including the use of NDT. Give priority and emphasis to bridges with Fracture Critical Members (FCM's) with intersecting welds.

Important points to note about the failure caused by these intersecting welds:

- The failure mode is brittle fracture which may be sudden and without warning.
- The failure is not fatigue related and may occur under low stress levels or with very low cumulative truck traffic.
- The failure is not material dependent and may occur in ductile material with good CVN properties.
- While the welds may crack, failure of the member in compression zones is unlikely.
- On a non-redundant FCM, the fracture of the weld may lead to complete structure failure.

Because the failure mode of intersecting welds is sudden and unpredictable nature, repairs and retrofits to cracked and uncracked locations must be given high priority.

2.11.1.5. Components of Fatigue and Fracture Inspections

2.11.1.5.1. Fatigue and Fracture Inspection Plan: Plan Requirements

The Fatigue and Fracture Inspection Plan provides a method for establishing and monitoring the history of the behavior of fatigue and fracture prone details on a fracture critical structure. A fatigue and fracture inspection plan is the first step in performing a thorough and complete investigation. Fatigue prone and fracture critical bridges need to have plan sheets of critical areas for the inspector. This assures that the conditions at all critical components will be inspected adequately and the field results presented in an organized manner to enable the program manager to ascertain the bridge's safety.

A Fatigue and Fracture Inspection Plan shall include the following:

Sketch(es) of superstructure with locations of all fatigue and fracture prone details identified

- Use framing plan or schematic with detail locations labeled and a legend explaining each labeled item on the scheme.
- Use an elevation view for trusses
- Classify similar fatigue/fracture prone details as types (e.g. end of partial cover plate)

A table of fatigue/fracture prone details indicating

- Type of detail (e.g. end of partial cover plate, short web gap, etc.)
- Location of each occurrence of detail
- AASHTO Fatigue Category of detail

- Identify retrofits previously installed

The inspector should plan to have proper access to reach the details to be inspected. In addition, the inspector should have a magnifying glass and dye penetrant kits on site. Lighting to ensure details are visible may also be critical on some bridges.

The condition of each FCM inspected should be noted on the field documentation (BR-86, Field sketches). Information shall note cracking or crack growth, debris on the member, etc. Photos and sketches, properly referenced to field notes and plan sheets, are a part of a good F&F inspection. The results of the field inspection should be carefully documented and compiled in accordance with the F&F Inspection Plan.

2.11.1.5.2. Fatigue and Fracture Inspection Plan: BMS Data

ITEM #188 - FRACTURE CRITICAL INSPECTION (CROSS REFERENCE TO INVENTORY DATA)

- A fracture critical bridge is defined as having one (1) or more fracture critical members.
- A fracture critical member is a steel member or component in tension, whose failure will result in a sudden collapse of all or part of the structure.
- Welded structures are particularly susceptible to fracture criticality as are bridges containing only two (2) main members (non-redundant).
- If the fracture critical switch is coded Y the fracture critical inspection frequency must be coded for the structure.
- Code and right justify a two (2) digit number indicating the number of months between inspections.
- If fracture critical switch is coded N leave item blank and it will default to zeros.

Date of Inspection

- Code the most recent date of fracture critical inspection for the structure including month, day and year.
- If fracture critical inspection is coded N leave this item blank

2.11.1.6. Fatigue and Fracture Inspection Plan; Frequency of Fatigue and Fracture Inspections

Fracture Critical Inspections are to be conducted every 24 months. Fracture Critical Members/Details in Fair or lesser condition or where estimated remaining fatigue life is less than 10 years or where displacement-induced (out-of-plane bending) fatigue problems are critical should be inspected at 12 to 18 month intervals.

Fatigue and fracture prone details require a hands-on inspection to discover the onset of cracking. Fatigue and fracture inspections may be a component of a Routine Inspection or In-Depth Inspection. It may also be a stand alone Special Inspection. The engineer in charge should determine the intensity of the inspection for each FCM detail. Factors for consideration include criticality of detail, tension stress level, overall member condition, estimated remaining fatigue life of detail, ADTT, retrofits, inspection frequency, etc.

2.12. Inspection of Bridges over Water

Nationwide, more bridges are lost each year due to scour than any other reason. Many times, these bridge losses occur during regional or localized flooding and their loss from the transportation system can make recovery from the original weather event even more difficult. To combat this loss of structures from the transportation system and protect our valued infrastructure, Ohio uses a threefold approach:

First an office assessment and management priority assessment of the bridge's vulnerability to scour is made so that critical bridges can be identified for closer monitoring and scour countermeasures.

Second a field review, scour vulnerability analysis, and prioritizing of bridge substructure units are used to verify the structural condition of the underwater elements, to verify integrity of their foundations and identified for closer monitoring and anti-scour maintenance needs.

Third a detailed scour analysis of bridges is very susceptible to scour. Additional monitoring may be required.

Other means of an underwater inspection

2.12.1. Assessment for Bridge Scour

One of the more effective ways of preventing the loss of a bridge due to scour failure is to identify those bridges most likely to be vulnerable to scour. With this determination, called a scour assessment, the bridge inspectors and owners can concentrate inspection/monitoring efforts and remedial actions to mitigate conditions at bridges with critical vulnerability. Scour assessments are required by the NBIS because they are deemed to be a key part of a comprehensive underwater inspection program.

The main purpose of the scour assessment of an existing bridge is to determine whether the bridge is vulnerable to scour. A scour critical bridge is one whose foundation(s) has been determined to be unstable for the predicted scour conditions.

There are two areas to code for bridge scour; the Bridge Inventory Manual (Item 74, Scour Critical Bridge) and this manual in Part II, Physical Assessment, Item 40 and 48, Scour. The Inventory data in the coding manual is to be used to record the bridge's

vulnerability against scour. The physical condition is to be rated with the inspection report. The scour susceptibility has corresponding codes with respect to the Inventory form (BR-87), Item 74. The four categories and corresponding Scour Critical Susceptibility (Item 74) codes are as follows:

1. Low Scour Risk
Item 74 corresponding codes 4, 5, 7, 8, 9
2. Scour-susceptible (Analysis needed)
Item 74 corresponding codes 6
3. Scour-critical (Scour plan of action is required)
Item 74 corresponding codes 0, 1, 2, 3
4. Unknown Foundations
Item 74 corresponding codes U

The results of the scour assessment are to be used in conjunction with information from regular and underwater bridge inspections to ensure that current stream (and bridge) conditions are used to evaluate the ongoing vulnerability of the bridge. Changes in stream and streambed conditions (including, but not limited to: scour depth/location, aggradation, degradation, debris, installation of countermeasures, etc.) discovered during inspection can dramatically affect the vulnerability of a substructure unit foundation and must be considered. Accordingly, the inspection information and the scour assessment must be used together for the evaluation of the overall safety of the bridge. The inspection information is needed to validate the input parameters and results of the scour assessment. The scour assessment results are used to determine if scour poses a threat to the bridge.

The two acceptable methods of performing scour assessments are:

1. Sour evaluation-Observed Scour for Bridges Methodology
2. Scour analysis-Theoretical Scour Calculations

2.12.2. Scour Evaluation Using Observed Scour Assessment for Bridges

The Department developed an alternative method of scour assessment based upon the observance of geomorphic, hydrologic, and hydraulic features at the bridge site. This assessment is seen as a cost effective approach to meeting the NBIS requirements for evaluating existing bridges without analytical scour computations. The following approach is recommended for the development and implementation of a program to assess the vulnerability of existing bridges to scour:

Bridges which are particularly vulnerable to scour failure should be identified. These particularly vulnerable "scour-susceptible" bridges are:

1. Bridges currently experiencing scour or having a history of scour problems during past floods as identified from maintenance records, local experience, bridge inspection records, etc.

2. Bridges over erodible streambeds and streams with design features that make them vulnerable to scour, including:
 - Piers and abutments designed with spread footings or short pile foundations
 - Superstructures with simple spans or nonredundant support systems that render them vulnerable to collapse in the event of foundation movement; and
 - Bridges with inadequate waterway openings or with designs that collect ice and debris. Particular attention should be given to structures where there are no relief bridges or embankments for overtopping, and where all water must pass through or over the structure.
3. Bridges on aggressive streams and waterways, including those with:
 - Active degradation or aggradation of the streambed
 - Significant lateral movement or erosion of streambanks
 - Steep slopes or high velocities
 - Instream sand and gravel and other materials
 - Mining operations in the vicinity of the bridge
 - Histories of flood damaged highways and bridges
 - Bridges that regularly collect significant debris on piers
4. Bridges located on stream reaches with adverse flow characteristics, including:
 - Crossings near stream confluences, especially bridge crossings of tributary streams near their confluence with larger streams
 - Crossings on sharp bends in a stream

Prioritize the scour-susceptible bridges and bridges by foundation types. To determine those foundations which are stable for the scour assessment, the following guidance is provided to the substructure unit foundation:

1. For spread footing foundations:
 - If the bottom of footings is not in the flood plain - Not scour critical
 - If the bottom of footings founded on soil or erodible rock within the flood plain - Scour critical
 - If the bottom of footings is founded on rock or is socketed into hard shale within the flood plain – Not scour critical
2. For deep foundations (piles or caissons):
 - If piles or caisson are bearing or are socketed in to rock - Not scour critical
 - If the piles are friction piles, a calculated scour analysis should be performed. Field evaluation will greatly influence coding (see Physical Evaluation, Item 40, for more discussion) May become Unstable and Scour Critical

Enter the results of the scour assessment in the BMS in accordance to The ODOT's Bridge Inventory Manual. Bridges assessed as "low risk" for Item 74 (scour-critical bridges) should be coded as a 9, 8, 7, or 5.

Bridges considered scour-critical based on an evaluation should be coded as a 0, 1, 2, or 3 for Item 74

Bridges with unknown foundations (except for interstate bridges) should be coded as a "U" in Item 74, indicating that a scour evaluation/calculation has not been made. It is recommended that only those bridges with unknown foundations which have observed scour, receive scour evaluation prior to the deployment of instrumentation currently being developed to determine foundation type and depth.

2.12.3. Scour Analysis Using Theoretical Scour Calculations

A scour assessment of a bridge using the theoretical scour calculations is a method based on hydrologic and hydraulic analyses of the stream and bridge opening. The method is described in The Bridge Design Manual in section 203.3 Scour and FHWA publication NHI 01-001 "Evaluating Scour at Bridges" fourth edition. In good design practice, the bottom elevations of foundations are established considering the calculated scour depth. These design scour computations may be used for the scour assessment and should remain in the bridge inspection file.

If existing scour at the bridge is deeper than the calculated scour, the theoretical scour analysis is not correctly modeling the real conditions and the scour assessment should be re-analyzed. Any significant change in site conditions should also warrant re-visiting the scour calculations.

For the scour assessment, the following guidance is provided for checking the resultant calculated depth of the theoretical scour to the substructure unit foundation:

For spread footing foundations:

- If the calculated scour is above the bottom of footings - Not scour critical
- If the calculated scour is below the bottom of footings founded on soil or erodible rock - Scour critical

For deep foundations (piles or caissons):

- If the calculated scour is above the bottom of footings - Not scour critical
- If the calculated scour is below the bottom of footing and above the bottom of pile/caisson a structural analysis of the foundation unit is needed to determine its stability. If not stable - Scour Critical
- If the calculated scour is below the bottom of pile/caisson. Unstable-Scour Critical

2.12.4. Scour Plan of Action for Scour Critical Bridges

Bridges considered scour-critical based on an evaluation/assessment coded as a 0, 1, 2, or 3 for Item 74 shall have a Scour Plan of Action. The plan shall include:

- Timely installation of temporary scour countermeasures such as monitoring or riprap and monitoring.
- Plans for monitoring scour-critical, unknown foundation, during, and after flood events, and for blocking traffic, if needed, until scour countermeasures are installed.
- Immediate bridge replacement or the installation of permanent scour countermeasures depending upon the risk involved.

A Scour Plan of Action form is provided

2.12.4.1. Scour Plan of Action form definitions

SFN- Structural file number

Bridge No. - County-Route-Section

Owner - Name of agency who owns the Bridges.

Facility Carried - Name the road the bridge carries.

Waterway - Name the creek/river that intersects the bridge.

Completed By - Name of agency that is responsible for completing the Plan of Action.

Date - Provide the date of when the Scour Plan of Action form was completed.

Section 1 - Scour Vulnerability Rating.

The evaluations should provide the details as to why the bridge is considered scour critical

- **Scour Evaluation Summary** - Summarize why the bridge became/is scour critical and provide some details of the present hydraulic concerns at the bridge site.
- **Scour History** - Report any known history of scour problems, drift/debris problems at the bridge site, channel meandering, bank erosion, approach washout, or any channel degradation and mining operation in proximity to site, etc.
- **Foundation type** - Identify the bridge foundation type.
- **Foundation material.** Identify the foundation material as best as possible. Foundation Reports and/or Log of Test Borings are a good source for this information. The county may also want to do a field visit to assess the ground material. This entry also can be left unknown.

- **Scour review** - Provide any known past hydraulic studies
- **Structural assessment** - Provide any known past structural assessment studies in relation to the scour potential and the date done at the bridge site.
- **Critical Elevation** - If any study provides an elevation in which the bridge becomes unstable, provide that information.
- **Geotechnical Assessment** - Provide any known past geotechnical assessment studies and the date done at the bridge site.
 - **Critical Elevation** - If any study provides an elevation in which the bridge foundation becomes unstable, provide that information.

Section 2 - Scour Countermeasure Recommendation

Provide countermeasures in accordance with guidelines from Hydraulic Engineering Circular 18 and 23 (HEC 18 and HEC 23) published by the Federal Highway Administration.

- **Completed Scour Countermeasure** - Indicate and give details and dates of any recent scour countermeasure that has been implemented in regards to addressing the current scour critical status of the bridge. All applicable studies, lead agencies, and as-built should be noted.
- **Proposed Scour Countermeasures**
 - **Countermeasures Not Required** - Indicate and provide details as to why no scour countermeasures are required at this time.
 - **Install Scour Countermeasures** - Indicate and provide details and dates including reference to any hydraulic, structural or geotechnical studies that have been completed for the purpose of scour mitigation.
- **Close Bridge** - Provide dates, details and detour.

Section 3 – Countermeasure Implementation Schedule

Identifies the installation of the proposed countermeasures to be preformed by contract work or work to be done by in-house maintenance forces. An estimated date of completion should be given.

Section 4 – Monitoring Plan

Monitoring is an option of providing scour countermeasure at a bridge site. It can be used as the scour mitigation proposal or as a supplement to a more permanent scour countermeasure. Monitoring a bridge for scour encompasses a large and varied amount of options. It can be as simple as inspecting the bridge for hydraulic damage on a regular interval and/or after a significant hydraulic event, or as complex as monitoring the bridge at different discharge levels using various monitoring devices. A monitoring plan could be the precipitous leading to Bridge Closure.

- **Monitoring Plan Summary** - Provide details of the extent of monitoring. What information the monitoring will provide, and what action will be implemented if the information indicates a scour problem?

- **Monitoring Authority** - Identify responsible agency for implementation and action of monitoring. Indicate who is in charge of overseeing and carrying out the monitoring plan.
- **Regular Inspection program** - Indicate the frequency of the monitoring and will cross sections and comparison of historical cross sections be required. Indicate the items to watch for.
- **Increased Inspection Interval** - Indicate the need for and increased interval and items to watch for.
- **Fixed Monitoring Devices** - Identify the type of instrument. This type of monitoring can be dependant on increasing channel flows and an identified discharge that could potential cause scour concerns. The monitoring or interval is usually increased as discharge increases.
- **Other Monitoring Program** - Identify any other methods of monitoring.

Section 5 – Bridge Closure Plan

- **Closure Plan Summary** - Provide summary of closure.
- **Scour Monitoring Criteria for Considering Bridge Closure** - Should be filled out if monitoring is used in consideration for bridge closure.
- **Person Responsible for Closure** - Identify responsible person/position responsible for closure.
- **Contact People** - Identify responsible person/position in charge of the bridge during closure.
- **Responsible for re-opening after inspection** - Identify responsible person/position responsible for re-opening the bridge.

Section 6 – Detour Route

- **Detour Route Description** - Provide a map with a viable detour in case of bridge closure/failure.
- **Length of Detour** - Provide length of detour in miles. A list of signs needed for closure and locations on detour map.
- **Bridges on Detour Route** - Provide a list of Bridges along the detour that are over water.
- **Bridges Number**
 - **Waterway** - Identify the waterway beneath the bridge.
 - **Load Rating or other restriction**

2.12.4.2. Evaluation of Scour Countermeasures

The Department's coding instructions for BMS Item indicate that the scour countermeasures are to be properly designed or verified through analysis before they can be considered as effective against scour.

PLAN OF ACTION AND SCOUR COUNTERMEASURES

Scour countermeasures are needed at the bridge to make it less vulnerable to either damage or failure from scour. The plan of action should be developed among the hydraulic, geotechnical, and structural engineers. Examples include the following:

- Monitor for scour during regular bridge inspection
- Increase monitoring frequency
- Temporary countermeasures - riprap and monitor
- Selection of scour countermeasures
- Scheduling of scour countermeasure construction

For existing bridges, recommended countermeasures include For existing bridges, recommended countermeasures include the following example action selected should be based upon the risk associated with potential scour:

- Riprap at piers and/or abutments with monitoring after flood events (visual and /or cross sections),
- Installation of instrumentation during and after flood events
- Guide banks
- Channel improvements
- Strengthening bridge foundations
- Relief bridges (structures used to handle the overflow)

2.12.5. Underwater Inspections

Just as regularly scheduled Routine Inspections include the inspection and evaluation of all pertinent bridge components to ensure that the structure continues to satisfy present safety and service requirements. The purpose of underwater inspections is to provide similar information on underwater portions of a bridge to evaluate their overall safety and, especially, to assess the risk of failure due to scour.

2.12.5.1. Description of Underwater Inspections

During periods of low flow, underwater members will be inspected visually and by feel using probing rods, sounding lines, or other hand tools. When the physical condition of the substructure members or the integrity of their foundations cannot be determined using the probing tools due to high water, high flow, turbidity, etc., inspection by divers is required. New technology, including ground sensing radar, ultrasonic techniques, remote video recorders, and others are proven alternative methods for underwater inspections of substructure foundations for limited situations.

Key information to be determined in every underwater inspection (either by probing or diving) is the top of streambed relative to the elevation of the substructure foundations. Because scour can vary significantly from one end of a footing to the other, a single probing reading is not sufficient. Baseline streambed conditions should be established by waterway opening cross sections and by a grid pattern of probing readings around the face of a substructure unit. This baseline information is essential for future monitoring and assessment. The current streambed conditions and changes since the last inspection are critical inputs to the bridge scour assessment.

Each bridge should have local benchmarks established near each substructure unit to enable inspectors to quickly and accurately determine the depth of adjacent scour. These benchmarks can be as simple as a painted line or PK survey nail driven into the wall in a place visible during high water. The location of these scour-monitoring benchmarks should be referenced in the inspection records. Use previously established benchmarks when possible to provide a long-term record of scour conditions. If new benchmarks need to be established, provide conversion from new to old datum.

During Routine Inspections, particular attention should be given to foundations on spread footings where scour or erosion can be much more critical than at deep foundations on piles or caissons. However, be aware that scour and undercutting of a pier or abutment on a deep foundation can also be quite serious. The foundation's vertical support capacity normally will not be greatly affected unless the scour is excessively severe, but the horizontal stability may be jeopardized. This condition becomes particularly unstable when erosion has occurred on only one face of the substructure unit, leaving solid material on the opposite face. Horizontal loads may also have debris, or rock fills piled against or adjacent to substructure units whose loads were obviously not provided for in the original design. Such unbalanced loading can produce an unstable condition, requiring corrective action.

BMS AND UNDERWATER INSPECTIONS: The Bridge Management System uses the data items to record each underwater inspection and to verify Ohio's compliance with the underwater inspection reporting requirements of NBIS. The date of the underwater inspection must be entered into the BMS.

2.12.5.2. [Maximum Intervals for Underwater Inspections](#)

Underwater inspections are intended to investigate two critical issues regarding the condition of bridge substructures located in water:

- The condition of structural components (including pier shaft, abutment walls, footings, etc.) under water.
- The integrity of the substructure foundation (including underlying soil, piles, caissons, etc.) against scour at each substructure unit in water.

The inspection of the foundation of a substructure unit and the determination of its ongoing resistance to scour is critical for the overall safety of the bridge. Because the integrity of the foundation against scour can suddenly and dramatically change in a relatively short time (as compared to physical condition of the structure components), shorter intervals for inspection of the foundation are warranted. The recommended intervals for underwater inspection of the foundation of substructure units for bridges over water are based upon a scour assessment of each unit.

The condition of the structural components can routinely be verified during the investigation of the foundation material. All bridges with substructure elements submerged greater than five feet in depth are to have an underwater inspection. The frequency of underwater inspection of a substructure unit is not to exceed 5 years (60 months).

2.12.6. High Water Inspections

The program manager is to establish an internal procedure to monitor scour critical bridges during or immediately after periods of high water. The following elements are recommended for consideration as part of the procedures:

- A list and, preferably a map, of scour critical bridges that are to be monitored during periods of high water. Other bridges that are not classified as scour critical but that may have scoured previously or that may be susceptible to debris and aggradation should be considered for inclusion.
- Because high stream flows can be very localized and information about its severity and extent may not be immediately available, a method of reporting the occurrence and extent of high water is needed. Many times the first responders are maintenance forces, they can be trained to report high water events to the program manager. This method is useful for prioritizing structures to be checked by bridge inspectors.
- Local benchmarks established at scour critical bridges can enable non-bridge inspectors to record and report the height of water. The list of scour critical bridges could also indicate the location of the benchmarks and the water heights at which scour inspections are warranted. In addition, the benchmarks enable inspectors to quickly gauge the progress of scour at a substructure.
- A high water inspection plan can improve the program managers response, especially in times of area-wide flooding where inspection resources may be limited.

2.13. Inspection of Closed Bridges; General

When a public road bridge is closed to vehicular traffic but not removed from the site, continued inspection is required on an annual basis to assure adequate safety to the public having access on or beneath the structure. Accordingly, ensure that necessary barricades for vehicles and/or pedestrians are in place. The physical integrity of the structure must be annually assessed to

ensure that a partial or total structural failure will not occur and endanger the public, even with no one on the bridge.

If a bridge remains on the inventory of public roads, it must be inspected in accordance with NBIS and Department standards. Although a bridge is closed, the inspection must be current. Federal-aid funding eligibility is not maintained without current inspection records.

2.13.1. Inspection of Closed Bridge

A safety inspection of a closed bridge due to structural conditions is similar to a Routine Inspection in the kinds of inspection data that must be collected. In general, rate each inspection item without being influenced by the fact that the bridge is closed. The closure barricades must be checked for integrity and effectiveness to maintain public safety. Permanent, fixed type barricades of concrete median barrier, steel guide rail, or other fixed type barrier should be installed in a manner that positively prohibits vehicles from the bridge. If the bridge is to be closed to pedestrians, a steel chain link fence, or other suitable barrier that prohibits pedestrian access should also be installed. If pedestrians are permitted to use the bridge, the bridge's structural safety for AASHTO's pedestrian loading must be verified at each Closed Bridge Inspection. Appropriate signing must also be in place, both at and in advance of the closed bridge.

2.13.2. Inspection of Closed Bridges during construction

When a public road bridge has been closed completely for replacement, it is no longer necessary to keep the inspection record current. For bridge projects, a bridge being replaced essentially becomes the property of the contractor when the project starts. However, if public pedestrian traffic is to be maintained on a bridge otherwise closed to vehicles, the responsibilities for the safety of the bridge and the need for inspection should be specified in the construction contract. If not specified in the construction contracts the program manager shall conduct the appropriate inspection and cycle on the portion of the bridge open to the public.

If a bridge is partially closed to vehicular traffic for a staged construction project (either rehabilitation or replacement), it is still part of the public road and the open portion is to be inspected as a Routine Inspection on the annual cycle.

If a bridge has been completely closed for rehabilitation, re-inspection during the construction is not required. However, upon the essential completion of work and prior to the bridge going back into service, an Initial Inspection is to be performed. The inventory and inspection data describing the bridge's rehabilitated condition must be entered into BMS within 90 days of the bridge being reopened to traffic.

2.13.3. Scope and Frequency of Closed Bridge Inspections

The level of effort required to perform a Closed Bridge Inspection will vary, as do other inspections, according to the structure's type, size, design complexity, existing conditions, and location, but is generally much less than Routine Inspections of in-service bridges. The criticality of the conditions that necessitated the closing and the risk of collapse must be considered when determining the scope of inspection. The level of scrutiny that the portions of the bridge not critical to public safety receive may be reduced from the intensity of a Routine Inspection, at the discretion of the Program Manger.

The focus of the Closed Bridge Inspection is to determine if the bridge is safe to remain in place in its current condition. If the pedestrian traffic is allowed, the safety of the bridge to carry this loading is to be determined. Structural analyses of closed bridges with significant changes in structure conditions since the initial closure may be warranted.

The maximum interval of inspection of closed bridges is 24 months with no public traffic. More frequent inspections may be warranted for bridges in perilous condition. Operational Status must be codes as "K" or "X".

2.14. Railroad Bridge Inspections; General

The inspection of bridges that carry or cross railroads requires attention to safety and compliance with special rules of the railroad. For their own protection, inspectors are to use extreme caution when working near the railroad tracks, electrified lines, trains and other railroad related hazards or operations.

2.14.1. Railroad Notification

If portions of a highway bridge over a railroad need to be inspected within the railroad's right-of-way, notify the railroad prior to performing the inspection. Railroad right-of-way varies for each railroad. As a precaution, or when in doubt, regarding railroad right-of-way, notify the railroad.

2.14.2. Inspection findings Notification

Program managers shall notify the PUCO and the responsible railroad company in writing of any inspection findings that endanger the traveling public.

For state owned bridges the Districts shall copy the Office of Structural Engineering.

2.15. Inspections of Non-Highway Bridges and Structures over State Routes: General

This Section is applicable to all non-highway bridges and structures, except railroad bridges and sign structures, over State Routes.

For the purposes of this manual, the term, overhead bridge, will be used to encompass all types of non-highway bridges and structures.

INVENTORY REQUIREMENTS: NBIS requires that all bridges or structures greater than 20ft. in length over Public Roads are to be inventoried and their data stored in the Department 's BMS. All bridges, regardless of their length, over State Routes are to be inventoried and their data stored in BMS.

AGREEMENTS GOVERNING THE CROSSING: The District is to ensure that the non-highway bridges over State Routes and those bridges not involving railroads are governed by a formal agreement between the bridge owner and the Department. The responsibilities of the Owner including inspection, inventory, maintenance and compliance concerns should be clearly outlined in the agreement.

2.15.1. General Requirements for Overhead Bridge Safety Inspections

The inspection of these non-highway bridges is similar to Routine Inspections of highway bridges. Because of the many types and features of existing overhead bridges, this Section cannot list a complete set of specific inspection requirements.

Load ratings are considered part of the overhead bridge inspection process just as they are for highway bridges. If appropriate, underwater inspection requirements for substructures should be included. Overhead bridge safety inspection reports must be signed and sealed by a Professional Engineer.

For longer bridges and structures, the inspection report to the Department may be limited to only those spans over the highway ROW and the substructure units supporting those spans. The District Bridge Engineer must approve the elimination of portions of a bridge from these inspection requirements. Bridge owners are encouraged, but not required, to inspect remaining portions with the same intensity.

For building-to-building passageway bridges, the structural components may be covered by siding, masonry, etc. that would interfere with an inspection using normal bridge techniques. These architectural facades also prevent the deterioration normally suffered by bridge components exposed to the weather. The scope of these inspections must be developed on a case-by-case basis.

Safety inspection reports and data of all bridges over State Routes must be submitted to the Department for its review and acceptance.

While this Section was developed for bridges over State Routes, other roadway owners are encouraged to adopt it for use for non-highway bridges over their roadways.

2.15.2. Frequency of Bridge Inspections

All bridges and structures, not including sign structures, over State Routes are to have a bridge safety inspection on a frequency no greater than 12 months. The program manger may require inspections more frequently than 12 months if structure and/or site conditions warrant.

The inventory data for all bridges and structures over State Routes shall be verified on a frequency no greater than 12 months.

2.16. Bridge and Structure Emergencies

2.16.1. Reporting Bridge and Structure Emergencies

When a bridge is no longer able to carry its intended loads, it is imperative for public safety to prevent further damage or collapse by controlling traffic on the bridge. The need to prevent overloads on a weakened bridge justifies a thorough and urgent response.

For state owned bridges reference section 2.8.4.3 Damage reporting and section 4.4
Documentation of Critical Findings

3. Bridge Restrictions

3.1. Bridge Restrictions; General

The use of warning signs shall be based on an engineering study or on engineering judgment.

Additional information is provided in the Ohio Manual of Uniform Traffic Control Devices (OMUTCD) presenting ODOT policies, standards, guidelines, practices and procedures concerning the design, construction, operations and maintenance of various types of traffic control signing.

The OMUTCD provides general information on the design of traffic control signs, including the basic concepts of shape and color. It also provides specific information on the application of standard signs. Information on the location of signs, including height, lateral offset, and longitudinal placement, is included as well.

The OMUTCD applies to jurisdictions statewide, some of the requirements contained therein are general rather than specific in nature.

3.2. Bridge Restrictions; Statutes and Regulations

§ 5591.42 Carrying capacity of bridges; warning notice.

The board of county commissioners together with the county engineer or an engineer to be selected by the board, or the director of transportation, may ascertain the safe carrying capacity of the bridges on roads or highways under their jurisdiction. Where the safe carrying capacity of any such bridge is ascertained and found to be less than the load limit prescribed by sections 5577.01 to 5577.12 of the Revised Code, warning notice shall be conspicuously posted near each end of the bridge. The notice shall caution all persons against driving on the bridge a loaded conveyance of greater weight than the bridge's carrying capacity.

HISTORY: RS § 4944; S&C 193; 66 v 90; GC § 7572; 101 v 220; 119 v 182; Bureau of Code Revision, 10-1-53; 135 v H 200 (Eff 9-28-73); 139 v S 114 (Eff 10-27-81); 143 v H 258. Eff 11-2-89.

Ohio Revised Code, Section 5591.42:

****or the Director of Transportation, may ascertain the safe carrying capacity of the bridges on roads or highways under their jurisdiction. Where the safe carrying capacity of any such bridge is ascertained and found to be less than the load limit prescribed by sections 5577.01 to 5577.12, of the Ohio Revised Code, warning notice shall be conspicuously posted near each end of the bridge as per section IV.C.

3.3. Bridge Restrictions; Signing**Narrow and One-Lane Bridges**

Highways, narrow bridges shall be identified using the NARROW BRIDGE sign (W5-2) in accordance with OMUTCD Section 2C.14, and the ONE LANE BRIDGE sign (W5-3) shall be used at one-lane bridges in accordance with OMUTCD Section 2C.15.

The NARROW BRIDGE (W5-2) sign may be used on an approach to a bridge or culvert that has a clear width less than that of the approach roadway.

The ONE LANE BRIDGE (W5-3) sign should be used on low-volume two-way roadways in advance of any bridge or culvert:

- Having a clear roadway width of less than 16 ft; or
- Having a clear roadway width of less than 18 ft when commercial vehicles constitute a high proportion of the traffic; or
- Having a clear roadway width of 18 ft or less where the approach sight distance is limited on the approach to the structure.

Object Markers Adjacent to the Roadway (Bridge End Markers)

Objects not actually in the roadway may be so close to the edge of the road that they need a marker to warn the driver of a potential danger. These include underpass supports, ends of bridges, handrails, and the concrete structure found at the end of a pipe. Such roadside objects and conditions are indicated by the following markers:



IF THE HAZARD IS TO THE LEFT KEEP
KEEP TO THE LEFT

IF THE HAZARD IS TO THE RIGHT
TO THE RIGHT

3.4. Bridge Posting Evaluations

Bridges that do not have sufficient capacity under the design-load rating should be load rated for legal loads to establish safe operating loads

3.4.1. Elements of a Bridge Posting Evaluation

Deck – Stringer supported concrete deck slabs or metal decks that are carrying normal traffic satisfactorily need not be routinely evaluated for load capacity.

Timber decks that exhibit excessive deformation of deflection under normal traffic loads are considered suitable candidates for further evaluation and often control the rating.

Substructures- Members of substructures need not be routinely checked for load capacity. Substructure elements such as pier caps and columns should be checked in situation where the Engineer has reason to believe that their capacity may govern the load capacity of the entire bridge.

Superstructure - Typically, only the main live load-carrying superstructure members are analyzed and rated to determine the need for a bridge restriction

3.4.2. Weight Restrictions Based upon the Condition of the Bridge

The engineer must determine if the condition and/or structural makeup of bridge elements other than the main live load carrying members control the bridge's capacity safety to carry live loads. Bridge components to consider include, but are not limited to: the deck, pier cap, arch spandrel

walls, cross-frames and diaphragms, substructure units, etc. If these elements control the bridge's capacity the restriction must be based on the controlling component

For bridges with general appraisal of a 4 or less shall have an updated analysis based upon current conditions

3.4.3. Bridge Restrictions Types of Weight Postings

OMUTCD; Section 2B.43 Weight Limit Signs (R12-1 through R12-5)

Option:

The Weight Limit (R12-1) sign carrying the legend WEIGHT LIMIT XX TONS may be used to indicate vehicle weight restrictions including load. Where the restriction applies to axle weight rather than gross load, the legend may be AXLE WEIGHT LIMIT XX TONS or AXLE WEIGHT LIMIT XXXX LBS (R12-2).

To restrict trucks of certain sizes by reference to empty weight in residential districts, the legend may be NO TRUCKS OVER XX TONS EMPTY WT or NO TRUCKS OVER XXXX LBS EMPTY WT (R12-3).

In areas where multiple regulations of the type described above are applicable, a sign combining the necessary messages on a single panel may be used, such as WEIGHT LIMIT XX TONS PER AXLE, XX TONS GROSS (R12-4).

Posting of specific load limits may be accomplished by use of the Weight Limit symbol sign (R12-5). A sign containing the legend WEIGHT LIMIT on the top two lines, and showing three different truck symbols and their respective weight limits for which restrictions apply may be used, with the weight limits shown to the right of each symbol as XX T. A bottom line of legend stating GROSS WT may be included if needed for enforcement purposes.

Standard:

If used, the Weight Limit sign shall be located in advance of the applicable section of highway or structure.

Guidance:

If used, the Weight Limit sign with an advisory distance ahead legend should be placed at approach road intersections or other points where prohibited vehicles can detour or turn around.

3.4.4. Procedures for Posting Restrictions on Department Bridges

The following standard Operating Procedure defines the department's procedures to be

performed for rating the relative strength of bridges and for posting warnings of bridge strength deficiencies.

3.4.5. Procedure for Rating

A. The relative strength ratings for each bridge shall be determined in the following manner:

1. A careful field inspection of the bridge shall be made by the program manger and/or other qualified structural engineer to determine its condition, and the percent of effectiveness of the various members for carrying load. All information shown in the Bridge Inventory and Inspection Records shall also be carefully checked and revised as necessary to show the current condition of the bridge.

A load rating shall be revised when a structure drops below a general appraisal of a 4 or less.

2. Using pertinent current information, the program manager and/or other qualified structural engineer shall determine the Inventory, Operating, and Ohio Legal Load Ratings for the structure as follows:
 - a. The Inventory Rating shall be determined by Load Factor Methods and shall be expressed in tons, in terms of the AASHTO-HS Loading.
 - b. The Operating Rating shall be determined by Load Factor Methods and shall be expressed in tons, in terms of the AASHTO-HS Loading.
 - c. The Ohio Legal Load shall be determined by Load Factor Methods and shall be expressed in terms of the Percent of Ohio Legal Loads.
3. The yield stresses for the construction materials in older bridges, for which plan information is not available, can generally be conservatively estimated using the date of construction and AASHTO tables.
4. The program manger shall submit to the Structure Rating Engineer a complete condition report and the original copy of the rating calculation sheets or computer input data sheets for each bridge under his/her jurisdiction.
5. The Structure Rating Engineer shall review the submitted material and return a copy of the final calculations or computer output to the Program Manger, along with any recommendations concerning the proposed ratings.

3.4.6. Implementation of Posting

- A. When the Operating Rating of the bridge is determined to be less than 100% of legal load and the bridge cannot be strengthened immediately to a rating of 100% or above, the following procedures shall be used:
1. The program manger shall:
 - a. Establish a rating and submit to the Structure Rating Engineer, a written request for the bridge posting. (See Section VII. below for required content of request)
 - b. After the Director signs the posting request, the District shall prepare, erect and maintain all necessary signs until the bridge is either strengthened or replaced.
 2. The program manger shall update all Bridge Inventory and Inspection records to show the latest official posted capacity. (See Standard Operating Procedure OPS-115.)
 3. After the posting request is signed, the Structure Rating Engineer shall send a copy to the: program manger; Manager of Hauling Permits Section of the Office of Highway Management; Superintendent of State Highway Patrol; Executive Director Ohio Trucking Association; the Board of County Commissioners; and the County Engineer where the structure is located.
- B. Special treatment shall be applied to legal load ratings of 95% or higher and also to legal load ratings of 15% or less as follows:
1. Because of the use of some judgmental data in the rating computations, bridges with a calculated load reduction of 5% or less, after rounding, shall not be posted. These structures shall be rated at 100% of legal load.
 2. For calculated load reductions of 85% or more, after rounding, the bridge must be considered for “closing” to all traffic until it can be rehabilitated or replaced.
- C. Where posting of a bridge is determined necessary and no unusual or special circumstance at the bridge dictates otherwise, Ohio standard regulatory signs shall be placed in sufficient numbers and at the specific locations required below.
1. Example of standard wording to be used on signs.

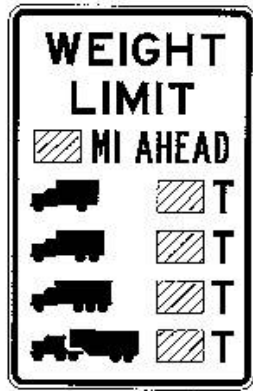

Bridge Ahead Sign (R-79)

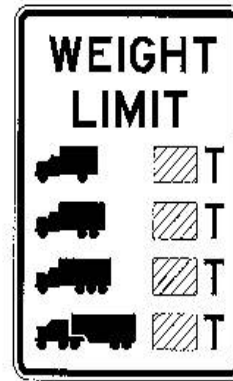

Bridge Weight Limit Sign (R-78)

2. Bridge Ahead signs shall be erected at intersecting state roads located just prior to the bridge to allow approaching vehicles to by-pass the bridge or turn around safely with a minimum of interference to other traffic.
3. Bridge Weight Limit signs shall be erected at each end of the structure.

3.4.7. Procedure for Rescinding Posting

- A. When a posted bridge has been strengthened or replaced and no longer needs posting, the program manger shall forward to the Structure Rating Engineer a written request to rescind the existing signed posting. The request shall include a complete statement of the reason for the action as specified:
- B. The Structure Rating Engineer shall review the data submitted by the program manger and upon concurrence shall forward to the Director a request to rescind the posting.
- C. The Structure Rating Engineer shall distribute copies of the rescind notice as described in Section 3.4.9 .

3.4.8. Procedure for Changing Posting

When the rated load capacity of a bridge needs to updated, so as to require a revised posting level, the procedures in Sections 3.4.4 and 3.4.5 apply and in addition, the existing posting must be rescinded as set forth in Section 3.4.7 .

3.4.9. Required information for Posting, Rescind, Procedure for Rescinding Posting

The following minimum information is required on all post, rescind and change requests.

A. Posting Request (Reduction in Load Limits)

1. County in which bridge is located
2. Current Bridge Number
3. Structure File Number
4. Feature intersected (over or under bridge)
5. Tonnage unit requested for the four typical legal vehicles.
6. Existing rating of bridge expressed as a percent of legal load or tons.
7. Explanation as to why posting is required
8. Attach copies of all official documentation for any associated actions by involved agencies other than the state.

B. Rescinding Request (Removal of Existing Load Limits)

1. County in which bridge is located
2. Current Bridge Number
3. Structure File Number
4. Feature intersected (over or under bridge)
5. Existing posting (% reduction or weight limit currently in effect)
6. Date existing posting was effective
7. Explanation as to why posting restrictions can now be removed (show contract project numbers or indicate force account or other work method used to correct problem)
8. New load rating for the rehabilitated or new structure

C. Change Request (Revision of Existing Posted Limits)

1. County in which bridge is located
2. Current Bridge Number
3. Structure File Number
4. Feature intersected (over or under bridge)
5. Existing posting (weight limit currently in effect)
6. Revised posting request
7. Date of existing posting
8. Explanation as to why posting changed

3.5. Procedures for Posting Restrictions on Locally-Owned Bridges

The departments Standard Operating Procedure outlined in Section 3.4.4 and Section 3.4.5 may

be adopted for locally owned bridge. Each agency shall have on file a procedure for performing load ratings of bridges and for posting warnings of bridge strength deficiencies.

3.5.1. Posting Approval Authority

RC 4511.07 authorizes local authorities such as county commissioners to carry out certain activities with respect to streets and highways under their jurisdiction. 4511.07 (B) authorizes them to "regulate traffic by means of police officers or traffic control devices." Regulation of traffic requires the passage of a resolution by the County Commissioners. Once the resolution has been passed authorizing the installation of a traffic control device, the device must conform to the Manual, (RC 4511.11 (D) establishes that *all* traffic control devices erected on a public road, street, or alley, shall conform to the state manual and specifications. Local authorities must place and maintain traffic control devices in accordance with the manual.)

3.6. Vertical Clearance Restrictions

Recommendations on Posting Low Clearance and Advance Warning Low Clearance Signs

1. All bridges, tunnels, overhead obstructions and openings for traffic that have the actual minimum vertical clearance of 14'-6" (4.4 meters) or less (rounded down to the nearest 1" or 25 mm) shall have Advance Warning Low Clearance signs (W12-2) and Structure-mounted low clearance signs (W12-2p) as per the guidelines of the Traffic Engineering Manual (TEM) and the Ohio Manual of Uniform Traffic Control Devices (OMUTCD) to warn the road users.
2. Ground posted Low Clearance signs (W12-2) may be used near the bridge in addition to Structure-mounted low clearance signs (W12-2p).
3. All the Low Clearance signs (W12-2 & W12-2p) should display the same clearance height.
4. Side Low Clearance signs (W12-H3) shall be used as per the guidelines of the TEM and Subtract 3" (75 mm) from the actual clearance (rounded down to nearest 1" or 25 mm) to display on the Low Clearance signs.
5. On bridges, tunnels, overhead obstructions and openings for traffic, which have actual vertical under-clearance more than 14'-6" (4.4 meters) and get frequent hits or have special needs or if requested, Low Clearance signs per these guidelines may be used.
6. Always input the actual clearance measurements in the respected BMS data fields.

The Department continues its efforts to provide accurate information through the Bridge Management System (BMS). The Department's Permit Office depends on the bridge clearance information in the BMS for their safe and uninterrupted operation. Bridge clearances should be periodically checked when performing routine inspections.

Traffic Engineering Manual

Section 202-7 of the ODOT Traffic Engineering Manual (TEM) states:

"The Advance Warning Low Clearance sign (W12-2) shall be used to warn road users of clearances less than 14 feet-6 inches (4.4 meters). The structure-mounted Low Clearance sign (W12-2p) shall be used for clearances of 14 feet-6 inches (4.1 meters) or less, and may be used for clearances greater than 14 feet-6 inches (4.1 meters). The W12-2p sign should be centered over the approach lane(s) with the low vertical clearance. The W12-2 and the W12-2p should display the same clearance height. The vertical clearance shown should be the minimum clearance measured to the bottom of a chord not less than 10 feet (3.0 meters) in width over the approach lane(s).

The Side Low Clearance sign (W12-H3) is intended to show the vertical clearance directly above the face of the side rail or curb. This sign shall be used on the structure where the vertical clearance at the face of the side rail or curb is 14 feet-6 inches (4.1 meters) or less. This sign should be used as necessary on variable clearance structures where the side clearance is more than 14 feet-6 inches (4.1 meters), but less than 14 feet-6 inches (4.4 meters). When W12-H3 signs are used on a structure, the W12-2p sign should also be used even if the center clearance is more than 13 feet-6 inches (4.1 meters)."

Ohio Manual of Uniform Traffic Control Devices 2003

Section 2C.20 of the Ohio Manual of Uniform Traffic Control Devices 2003 Edition (OMUTCD) states:

"Standard: The Low Clearance (W12-2) sign shall be used to warn road users of clearances less than 300 mm (12 in) above the statutory maximum vehicle height or minimum structure height.

Guidance: The actual clearance should be shown on the Low Clearance sign to the nearest 1 in not exceeding the actual clearance. However, in areas that experience changes in temperature causing frost action, a reduction, not exceeding 3 in, should be used for this condition."

3.6.1. Maximum Legal Height of Vehicles

Ohio Revised Code reference for the vehicle height restriction is ORC Section 5577.05(D), Section 5577.05 addresses Maximum width, height and length.

4. Quality Measures for Safety Inspection

4.1. Quality Measures: General

The focus of the departments Quality Assurance Review (QAR) program is on performing quality control and quality assurance checks during processing, handling, documenting,

archiving and reporting procedures that are common to all bridge inspection programs. The bridge inspection process is the foundation of the entire bridge management operation and the bridge management system. Information obtained during the inspection will be used for determining needed maintenance and repairs, for prioritizing rehabilitations and replacements, for allocating resources, and for evaluating and improving design for new bridges. The accuracy and consistency of the inspection and documentation is vital because not only does it impact programming and funding appropriations but also it affects public safety. The results of these QC activities and procedures should be documented.

QAR are used to determine the Department's, bridge owners, conformance with the National Bridge Inspection Standards (NBIS) and the annual bridge inspection cycle. The purpose is to ensure the Department's, bridge owners, bridge inspection reports accurately reflect the actual condition of the structures, proper types of inspections are performed, and to determine if identified maintenance needs are being addressed. Areas covered during a QAR include but are not limited to: compliance with annual bridge inspection cycle; underwater inspection cycle; scour evaluation; fracture critical structures; snooper inspections and other special requirements; completeness and accuracy of bridge inspection reports (BR-86). A QAR may consist of district office review, onsite field review, or use of BMS data statistics using Graphical Query Language (GQL) reports

All organizations involved with bridge inspection within the State of Ohio come under the jurisdiction of the Department's QAR program.

4.2. Quality Control

Quality Control (QC) is the enforcement of procedures that are intended to maintain the quality of a product or service at or above a specified level. Quality Control of the inspection of highway bridges is a daily responsibility performed in each organization performing the safety inspections, including consultants, owners, and District Bridge Units. A set of effective QC procedures is required to control the accuracy and precision of inspections, recording methods, and reports. To ensure statewide uniformity and consistency the Department provides basic inspection training.

Each bridge safety inspection organization (e.g. Department District Bridge Units, engineering consultant firms, or bridge owner's staff) is to have internal quality control procedures in place to assure that the public safety is maintained on the bridge and that the inspections are performed in accordance with NBIS and Department standards. An effective quality control program must as a minimum address the following areas:

- Review of Organization Personnel: Qualifications, training and staffing levels.
- Review of Field Inspections.
 - Review Office Files and procedures

- Review Bridge Maintenance/Rehabilitation/Replacement Needs and reporting process
- Critical Findings Documentation and Resolve.
- Annual Meeting with Bridge Inspection Staff.

Documentation concerning the inspection organization's quality control program and findings must be maintained

4.3. Quality Assurance

The purpose of the Quality Assurance Review Program is to evaluate program effectiveness, uniformity, and compliance with federal and state rules relating to bridge inspections. Quality assurance reviews may recommend program improvements and may require changes in a program.

The QAR procedures are established to provide an objective review of the quality of the inspection program, and identify areas where improvements could be made. The program may be reviewed as a whole or in parts. The objective in QAR implementation is to involve reviewers that can conduct an unbiased review of the bridge program.

The QAR reviewers should not be involved in preparing the inventory or involved in the inspection process of the program, preferably independent experts from other agencies. Where third party reviewers outside the jurisdictional agency are not available, qualified staff from another part of the agency independent from the inventory being reviewed can fulfill the QAR.

The Statewide Structure Inspection Quality Assurance Review Program, under the direction of the Statewide Program Manager (SPM), involves on-site reviews at the Department's District Offices and other counties, cities, villages, and townships.

4.3.1. QAR Review of Office File

An effective QAR program begins with assuring that an adequate, qualified and properly equipped staff is in place to address the primary functions of a bridge inspection program:

The Program Manger is to maintain a roster and organization chart of the staff performing bridge inspection. The Program Manger is to ensure that the staff meets NBIS and Department requirements for certification, training, and experience. The staffing complement must be sufficient and properly equipped to ensure that inspections are performed in a timely manner and in compliance with NBIS and Department requirements. The following items shall be reviewed:

Inspector Qualifications- The program manager must provide the SPM or DPM with Inspector Qualifications Forms Prior to the review. The SPM or DPM will request that all active structure inspectors submit documentation to support the experience listed on the

Inspector Qualifications Forms. This information will be reviewed by the SPM and FHWA to determine if IPM, ITLs, and ITMs meet federal qualification and state qualification requirements as described in this Manual.

Record Keeping - The program manager must verify to the SPM or DPM that complete, accurate, and current records are maintained for each bridge under their jurisdiction.” Records of recent and past bridge inspections including Routine and Special Inspections will be reviewed for legibility, accuracy, and accessibility. Inspection reports and records must be filed in an orderly manner. All state-owned bridge files must be stored at the district offices. Locally-owned bridge files must be stored under the authority of the County Commissioners (County Managers), or City Engineer. Where bridge plans, repair plans, and/or rehabilitation plans are available; a set must be placed in the file folder with all other information about the bridge. Additional information such as correspondence, agreements, memos, etc. must be placed in the bridge file.

Bridge Inspection Planning , staffing, equipment and budget- The program manager must verify to the SPM or DPM that inspections are planned using, techniques, equipment, sufficient staff and budget sufficient for the size of the program. The program manager must provide documentation such as Inspection schedules, time sheets or documents calculating average inspection time per structure, number of bridges in the program, inspection preparation practices, equipment and budgets available for the inspection program..

Routine Inspection Report Review - The SPM or DPM will select filed Routine Inspection reports for review as necessary to make certain that each item on inspection reports is addressed, recommended repairs are recorded, notes are legible, and forms are signed and dated.

Special Inspections Report Review - The SPM or DPM will select filed Special Inspection reports as necessary to determine if special inspections such as: Fracture Critical, In-Depth, Underwater-Dive, Underwater-Profile, Underwater-Probe/Visual, Movable, Initial, Damage, Interim, and Load Posted Inspections ,to make certain that each item on the inspection report is addressed, recommended repairs are recorded, notes are legible, and forms are signed and dated..

Load Posted/ Closed Bridge File - The SPM or DPM will select filed Load Posted/ Closed bridges as necessary to determine if these bridges require load posting or closure. The SPM or DPM will evaluate bridges with an operating rating less than the state legal load limits to determine if bridges are properly load posted. Bridges with low condition ratings for substructure and/or superstructure will be reviewed. Load rating analysis reports will also be reviewed.

Safety - The SPM or DPM will review the safety practices of the bridge inspectors during representative bridge inspections. The review will evaluate if: work zone traffic control is in accordance with the Manual of Uniform Traffic Control Devices. Appropriate personal safety gear is used by inspectors with written safety procedures. Additional safety equipment should be readily available for TML use.

4.3.2. QC Review of Field Inspections

The SPM or DPM will perform field inspections with the program manager and inspector(s) of record. The SPM or DPM will select from a list with identified deficient bridges, bridges that have unique problems or features or bridges that the SPM or DPM profiles for selection. From the established list of bridges, two to five bridges will be chosen for field review. All pertinent records contained in each bridge file will be taken to the field for the review. The reviewers will conduct an inspection of each chosen bridge.

The Field inspections will verify system compliance with Department or NBIS standards or rules as follows:

- Verify inspection forms are completed with all required information.
- Verify element level ratings and NBI ratings are consistent with the Department's bridge inspection criteria and conventions. Ratings and conditions determined by the reviewers may vary plus or minus one for the summary ratings and for the element level ratings.
- Discuss and make program level corrections as necessary to improve system compliance with Department or NBIS standards or rules.

4.3.3. QAR of Bridge Maintenance/Rehabilitation/Replacement Needs

A rational method for identifying bridge deficiencies and recommending repairs is required. The methodology should include how recommended repairs are prioritized, how they are assigned to repair crews or contractors, how completed repairs are documented (with initials and dates), and how completed repairs are recorded in the file. These methods will be reviewed for adequacy and compliance.

A review of how bridges are prioritized for rehabilitation and/or replacement will be conducted. Bridge replacement funds will be discussed to determine if the agency is taking full advantage of all funding sources

4.4. Documentation of Critical Findings

The National Bridge Inspection Standards (23 CFR 650 subpart C) states critical findings are to be documented and addressed in a timely manner. This documentation is to be completed upon the finding of a critical bridge deficiency.

A critical bridge deficiency involves a situation discovered during any inspection of a bridge that if not promptly corrected, could cause failure or partial failure of a bridge, or could pose a serious traffic safety hazard. Any of the following inspection findings must be reported immediately:

- Bridge with recommendations for immediate action (within one week) on any Fracture Critical Member.
- Bridge with recommendations for immediate (within 1 week) correction of scour or hydraulic problems.
- Bridges with recommendations for immediate (within 1 week) work to prevent substantial reduction in safe load capacity.
- Bridges with condition ratings lowered to a value of 2 or less for items: Deck Summary, Superstructure Summary, Substructure Summary, or Culvert Summary.

A critical findings report (See Appendix) shall be filled out and mailed, e-mailed, or Faxed to Ohio Department of Transportation, Office of Structure Engineering. Attention to State Bridge Inspection Engineer. A resolution date will be added when all repairs have been completed and kept on file for future audits.

4.5. Qualifications for Personnel Conducting Quality Assurance Reviews

Inspection program managers make important decisions ranging from suggestions regarding the allocation of scarce rehabilitation dollars to the decision to close a major structure. Therefore, it is important that reviewer are highly trained and experienced individuals who understand the mechanics, behavior trends, and economics of a wide variety of structure types.

The qualification of QAR reviewer:

1. Must have attended and passed a comprehensive two-week training course such as the FHWA "Safety Inspection of In-Service Bridges" (NHI Course Number 130055), or the ODOT Bridge Inspection Training Level I and Level II.
2. Must be a registered professional engineer in the State of Ohio with appropriate training and experience
3. Must have a minimum of 10 years experience in bridge safety inspection.

Counties, municipal corporations, or other bridge owners may contract with Consulting Engineers experienced in this field for Quality Assurance Reviews. If such Engineers are

retained to conduct a QAR a copy of the report shall be forward to The Ohio Department of Transportation, Office of Structural Engineering. The QAR performed by Consulting Engineers shall have the firm's name and the name of the reviewer on the QAR report.

4.6. Recommended Time Frame For Quality Assurance Reviews

- Quality assurance reviews are conducted annually in accordance with the following recommended schedule. The goal of the program is to perform a quality assurance review of all inspection programs once every four years. The QAR should use other agencies or an consulted independent experts.
- Four ODOT districts per year will be selected for a QAR of which two shall be performed with a representative from FHWA.
- Four local agencies shall receive a QAR from ODOT and FHWA representative each year.
- Each county shall receive a QAR a minimum of once every four years.
- Each city shall receive a QAR a minimum of once every four years.
- Each town and village shall receive a QAR a minimum of once every four years.

4.7. Disputed of Quality Assurance Findings

The owner may request a review in the event of a disputed condition evaluation. The review request would be a panel of bridge engineers. The panel will make a site visit to the bridge in question

5. Training and Certification Program

5.1. General

The purpose of this course is to provide for certification of bridge safety inspectors and to impart the basic knowledge and skills necessary to accurately report on bridges for statewide uniformity of inspection. Upon completion of the course, participants will have been trained to inspect bridges in accordance with the requirements of the National Bridge Inspection Standards and the Department.

5.2. Bridge Inspection Training Course

The course instructions are primarily based on the Federal Bridge Inspectors Training Manual and the Recording and Coding Guide. The instructions are supplemented with visual aids and related material pertinent to the various types of bridges common in Ohio. The course will familiarize participants with the Federal and State inventory and inspection forms, coding of

items, detection and evaluation of various defects or damage to the bridge structure and emphasize uniformity and accuracy of data collected and coded on inventory forms. Emphasis will be placed on active dialogue between participants and instructors especially concerning the numerical ratings of safety-related defects, structural defects and deficiencies and to promote uniformity of rating. The course includes a field inspection exercise to demonstrate practical application of classroom instructions.

The Department has an in-house comprehensive training course meeting the requirements for the NBIS Bridge Training Course. There are two separate 3-day parts (Level I and Level II). Level II has a mandatory test at the end of the class and all inspectors are required to pass in order to meet the Department's qualifications. The Department presents the course to all Department, local, and consultant inspectors who work in Ohio.

Each participant will receive a Certificate of Completion when attending the bridge Level I course, completing 24-hours of training. Each participant will receive a Certificate Satisfactory Completion when attending the bridge Level II course, completing 24-hours of training upon receiving a minimum satisfactory score of 70 percent at the conclusion of the course. This certification satisfies the NBIS training requirement for having completed a comprehensive training course based on the "Bridge Inspector's Training Manual"

Experience requirements specified in the NBIS and this Manual must be gained and documented by the inspector and validated by the department, local, and consultant owners performing inspections in Ohio

6. Inspection Records, Files, and Reports

6.1. Purpose of Inspection Records and Files

Program managers are to maintain complete, accurate, and up-to-date record for each of their bridges. The bridge inspection file is an integral part of an effective bridge inspection and management system. These records are needed to establish an inventory of infrastructure assets. Document the condition and functionality of infrastructure. The information in the bridge inspection file is kept current through bridge inspection cycle.

Program managers are to maintain complete, accurate, and up-to-date record for each of their bridges. These records are needed to:

- Establish an inventory of infrastructure assets
- Document the condition and functionality of infrastructure, including the need and justification for bridge restrictions, for public safety
- Identify improvement and maintenance needs for planning and programming
- Document improvements and maintenance repairs performed

- Meet documentation requirements for work performed using Federal and State funding
- Provide available information in a timely manner for safety inspections

Bridge inspection reports and some inventory data are warehoused by the department's bridge management system, an electronic database. These records are also forwarded to the FHWA on an annual basis. The BMS is not to replace any responsibly of the program manger to maintain the required bridge file system

6.2. Inspection Organization Unit File

The program manger, bridge owners are to maintain a general file of their organization for bridge safety inspection. The file shall define the scope of their jurisdiction. The organization file should contain:

- List of bridges and structures*
- List of posted bridges* with date of most recent signing verification
- List of FCM bridges *
- List of bridges with special features and/or conditions that necessitate special or more frequent inspections*
- List of bridges that require underwater inspection *
- List of bridges to be inspected during/after high water events
- Contact list for key staff during bridge emergencies
- Inspection organization
- Organizational Chart listing key staff, program managers and inspectors.
- Certification credentials for the program manager, inspectors and key staff.
- Agency QC Plan including findings and results
- Agency QAR Plan including findings and results
- List of inspection equipment
- List of bridge design and inspections reference materials
- Pass results of QA reviews

* May be generated from BMS data

6.3. Individual Structure Inspection File Contents

The inspection file for each bridge/structure typically consist of a wide variety of information from several sources to ensure sufficient information is readily available for safety inspections and overall bridge management. Because sources for most of the bridge information is more short lived than the bridge structure itself, the inspection file is the final repository from which information on the bridge's design, construction and maintenance can be retrieved to evaluate current conditions. The inspection information for individual bridges or set of bridges need not be located in a single central file. In fact, the wide variety of formats (including: 8 ½" x 11"

paper reports, 22" x 36" mylar/vellum drawings, microfilm aperture cards, microfiche, electronic drawings/documents, photos prints/negatives/digital images and management system databases) are now in use. A "single file drawer" concept for file management is typically impractical. For the purposes of this section, the generic term "Inspection File" is intended to encompass all of these records wherever they are physically stored.

Inspection File may be stored in more than one physical location. An index of the information available is critical to enable the inspector to quickly access information needed to evaluate a structure. A good index for each bridge should identify the types of records available, their format, storage location, and date of record. This index must be a document that is readily available to the program manager, inspectors, and key staff. Provide this index for review during the QAR procedures.

6.3.1. Record Retention Period

Unless otherwise noted, one copy (or the original) of each document in the bridge inspection file must be maintained for the life of the structure.

The following documents may be destroyed after the following retention period:

1. Routine inspections older than 10 years for bridges in service
2. Retain all inspections, load ratings, design computations and maintenance records for 3 years after a bridge is replaced.
3. Retain all load ratings for 3 years after a new rating is complete

For Department bridges that are turned back, given or sold to local municipalities or private/public organizations, all bridge inspection file information should be given to its new owner. The District needs only a file with contents similar to other local bridges. A record of the ownership transfer should be maintained in the bridge file.

6.3.2. Inventory Information and Field Inspection Records

These records are typically generated through the routine safety inspection program activities and include for each individual structure:

- Inspection record file index
- Location Map
- BR-87 Forms to document inventory information stored in BMS

Routine Inspection Reports may include, but are not limited to:

- Field inspection notes Field Inspection Forms including narrative (Hard copy)
- Inspection Photos (Elevation, Approaches, Upstream and Downstream, and Deficiencies)
- Inspection Sketches
- Clearance Envelope for bridges over highways or railroads

- Waterway Opening Cross-section and Stream Plan sketch
- Video of bridge site or conditions
- Destructive and Non-Destructive Test Results

Fatigue and Fracture Investigations include, but are not limited to:

- Plan for Fatigue and Fracture Inspections
- Determination of Remaining Fatigue Life
- Fatigue/Fracture Inspection Reports

In-Depth Inspection Report

Underwater Inspection Reports

List of special equipment needed for inspection

6.3.3. Load Rating Analysis

The Load Rating Analysis is part of the safety inspection of a bridge which include:

- Analysis and Rating (All calculations, and computer output and input files and supporting calculations).
- Justification for an Engineering Judgment must include documentation of the condition of the bridge and date of the inspection that the load rating is based upon.

6.3.4. Posting Evaluation

The Posting Evaluation must be included in the individual structure file include:

- Posting Evaluation
- Posting Recommendation Data Sheets
- Posting Approval Letter
- Related Correspondence

6.3.5. Design Related Information

Information generated during the design of the bridge that should be incorporated into the permanent inspection file includes:

- Design plans for original construction or rehabilitation
- Design Computations
- Design Exception Approval letters (Used in Rating Appraisal Items)
- Foundation Report
- Surveys

6.3.6. Waterway and Scour-Related Reports

Information that assists in evaluating the waterway opening and the bridge's resistance to scour must be included in the individual structure file include:

- Hydrology and Hydraulics Reports
- Observed Scour Assessment Report
- Scour depth computations (may be part of H+H or standalone calculations)

6.3.7. Construction and Maintenance Records

Records regarding construction and maintenance considered to be important for the bridge inspection file include:

- As-Built drawings
- Shop Drawings
- Pile Hammer Approvals and Pile Driving Records
- Field Change Orders
- Jacking and/or Demolition Schemes
- Documentation of latent defects
- Maintenance Work Orders, Sketches
- Repair Records

6.3.8. Miscellaneous Documentation

Preparation requirements for the field phase of an inspection vary greatly. Variations may be due to structure type, site accessibility, traffic volume, or channel conditions. Documenting field preparation requirements can reduce budgets by maximizing mobilization efficiency. The following areas of preparation, where applicable, are to be documented for each bridge.

- Required Tools and Equipment - Identify any specialized tool or piece of equipment necessary that is not ordinarily carried by the bridge inspector. Example tools might be extendable ladders, special non-destructive testing equipment, power tools, lights, special safety equipment, special underwater tools or diving gear.
- Special Services - Record any special services that are required. Example services might be traffic control, structure cleaning operations, inspection access such as structure rigging, an under bridge inspection crane, or special working platforms such as a barge.
- Scheduling - Document specific scheduling needs for non-routine inspections. This includes manpower needs for larger structures that require an extended duration inspection effort with multiple inspectors, bridges subject to seasonal flooding conditions, fracture critical bridges where special services are required, and underwater bridge inspections.

- Site Condition Considerations - Identify unique site conditions that require more than routine preparation. Unique site conditions include railroad property right of way restrictions, navigable waterway restrictions, high voltage transmission lines, unusually heavy vegetation, mud, pollution, insect or animal droppings, unusually high water level or unique traffic safety procedures

Other documents that may be maintained as part of the inspection file include;

- PUCO Documents
- Confined space permits
- Miscellaneous Bridge-Related Correspondence
- Cost Estimates for Improvements

6.4. Consultant Inspection Report Format

As a part of a major bridge inspection, the consultant is responsible for providing a detailed inspection report documenting the present condition of the bridge. The following guidelines are given:

- The report shall be printed on standard 8 1/2 inch by 11 inch paper with exceptions given to drawings or other information which is required to be printed on larger, fold-out sheets.
- Font used is to be no less than 11 point.
- Report is to be bound along the left hand side.
- Photographs used in the report are to be approximately 3.5" x 4.5" in size and a resolution of 150 dpi

The following outline should be used to construct the report.

1. Cover Sheet – The cover sheet will be of card stock and placed in a plastic jacket and include the items below:
 - a. Report Name (i.e. "2005 In-Depth Inspection Report")
 - b. Elevation photo of structure
 - c. Bridge Number
 - d. Bridge Name
 - e. Feature intersected
 - f. Owner (generally this will be Ohio Department of Transportation)
 - g. District number (if applicable)
 - h. Inspection dates

2. Signature Sheet – The signature sheet states who wrote and reviewed the report, and their signatures. Either the preparer or reviewer will affix their professional engineer’s stamp to this sheet. Include the items below:
 - a. Report Type
 - b. Bridge Number
 - c. Bridge Name
 - d. Feature intersected
 - e. Owner (generally this will be Ohio Department of Transportation)
 - f. District number (if applicable)
 - g. Inspection dates
 - h. Prepared by (name, title, and signature)
 - i. Reviewed by (name, title, and signature)
 - j. Professional Engineer’s stamp
 - k. Inspection dates
 - l. List of inspectors
 - m. Owner
 - n. Date report is submitted
 - o. Consultant’s name, address, and phone number

3. Table of Contents – Include the page number of the headings of the report. (From this sheet on, include a footer noting the bridge number, report name, bridge name, consultant name, and page number)

4. Summary –
 - a. Note the overall condition rating of the bridge
 - b. Highlight major findings from the inspection
 - c. Include specific examples as needed

5. General –
 - a. Note who performed the inspection
 - b. When the inspection occurred
 - c. Purpose of the inspection (to perform load rating, investigate damage to the bridge, etc.)
 - d. How it was inspected (any special testing, what access methods were used, diving performed, etc.)
 - e. Regulations, specifications, and guidelines followed
 - f. Inspection techniques used
 - g. Special testing performed, use of traffic control

6. Bridge Description –
 - a. Note bridge overall length and characteristics of bridge spans including structure type and length

- b. Date built
- c. A brief history noting when rehabilitation/repairs were made and what work was performed
- 7. Elevation and End View Photographs
- 8. Location – Include map and description of geographic location
- 9. Condition –
 - a. List the condition descriptions for the summary items (9-0 NBI rating descriptions), individual items under each summary item (good, fair, poor and critical descriptions), and protective coating system (9-0 rating descriptions developed by ODOT).
 - b. Overall Appraisal and Operational Status – Provide a brief paragraph describing the rating and a list of the summary items and their ratings.
 - c. Summary Items (Deck, Superstructure, Substructure, Channel, Approach, General, Suspension, Movable). Provide a brief narrative describing the summary rating and which individual element controls the summary rating (see Example 1).
 - d. Individual items (Floor, Wearing Surface, Curbs, Sidewalks, Walkways...). Under each summary item include the individual items as noted in the BR-86 form (see Example 2). A brief summary of the rating and specific deficiencies as bulleted items is needed. Bridge members are rated on their current physical condition and not on the adequacy of the design. Also, include relevant photos to help clarify the deficiencies being described.
 - e. For expansion joints and movable bearings, a table with appropriate measurements, temperature, and description will be needed.

Example 1

DECK SUMMARY

FAIR

The deck is rated a 5, meaning that it is in fair condition. The rating is based on the condition of the Floor which is rated 2 – Fair.

The individual items are as follows:

<u>Item</u>	<u>Rating</u>
Floor	2 - Fair
Wearing Surface	2 - Fair
Curbs, Sidewalks, and Walkways	3 - Poor
Railing	2 - Fair
Drainage	2 - Fair
Expansion Joints	1 - Good

Example 2

Floor	Fair
-------	------

The underside of the deck is in fair condition. The following deficiencies were noted:

- Spalling exists...

10. Recommendations –

- a. Immediate – note deficiencies that need to be addressed immediately because of a safety hazard.
- b. Maintenance and Monitoring – note work that should be performed periodically. These typically are performed by in-house forces.
- c. Short Term – note deficiencies that need to be addressed within the next 3 to 5 years. These recommendations are generally intended to maintain the current level of service the bridge is providing.
- d. Rehabilitation – note major work that needs to be planned for within the next 10 years. These recommendations are generally intended to restore or improve the level of service the bridge provides.
- e. Future inspection or testing – note any additional inspection or testing that should be performed based on the findings of this inspection.

11. Appendix – Include if applicable the following items below:

- a. BR-86 Form
- b. Testing Results
- c. Underwater Inspection Report
- d. Bridge Drawings
- e. Deterioration Drawings

7. Safety Inspection Equipment

7.1. General

In order to effectively perform a routine bridge inspection, it is important for the inspection team to be properly equipped for both data collection and safety. This section will focus on the essential equipment needed to perform a routine inspection and also discuss other items to perform more difficult, in-depth inspections.

Answers to the following questions will determine the proper inspection equipment needed:

- What type of structure will be inspected?
- What type of inspection?
- What method of inspection?
- What kind of equipment is needed to access the remote portions of the bridge?
- When will the inspection be done?

It is important that inspection teams are outfitted with the proper equipment to:

- Facilitate personal and public safety during inspection of the structure
- Perform an efficient and accurate inspection of the structure
- Perform the proper level of inspection intensity
- Correctly record the conditions of the structure

The equipment required and method of inspection, once it has been determined for a structure, should become part of the bridge inspection file for future use.

The Department developed a standard list of tools for inspection to assist the Districts, bridge owners, and consultants to properly prepare for field inspections. Inspectors should not be limited to the equipment on this list as special circumstances may necessitate either the use non-standard tools. The Districts may use the Department's Standard Tool List may be used to justify acquiring needed items.

7.2. Inspection Tools and Equipment

Listed below are items that should be standard and available for every bridge inspection. They are grouped according to use and purpose.

7.2.1. Visual Aids

- Flashlight with extra batteries
- Binoculars
- Inspection mirrors to enable the inspector to view inaccessible areas
- Magnifying glass
- Dye penetrant
- Miners type light to allow a hands-free inspection, particularly if climbing

7.2.2. Inspection

- Chipping and/or sounding hammer
- Pocket knife
- Utility or Tool Belt
- Ice pick
- Plumb bob

7.2.3. Measuring Devices

- 25 foot pocket tape measure
- 100 foot tape measure
- Thermometer
- Carpenter's level
- String line
- Calipers large enough to measure web and flange thickness and any element beyond an exposed edge
- Optical crack gauge
- Protractor
- Vertical Clearance Pole

7.2.4. Documentation

- Clipboard with cover to protect against inclement weather
- Writing instruments (pencils, sharpie markers, pens)
- Engineers Scale, pocket size
- Surveyors keel
- Digital Camera with extra batteries or charger
- Surveyors level with measuring rod
- "P-K" nails
- Marking paint

7.2.5. Safety

- Hard hat
- Safety vest
- Safety glasses
- Eye wash bottle
- First Aid kit
- Cellular phone with charger
- Gas Monitor
- Full body harness
- Static and dynamic ropes
- Insect repellent
- Wasp and hornet killer
- Sunscreen
- Life vest

7.2.6. Miscellaneous

- Existing plans
- Folding ladder
- Sounding chain
- Hip and/or chest waders
- Probing rod
- Cordless drill kit
- Machete
- Penetrating Oil

There may be situations where more specialized equipment and training are required. This may include the use of a snooper truck, rigging for climbing, small boat for inspections involving water, closed confined space inspection equipment and diving equipment for underwater inspections. Traffic control devices may be required where work is being performed on the bridge deck or where traffic lanes are temporarily closed.

PART II – Bridge Inspection Condition Assessment

Condition Assessment

Bridge Inspection Report: The inspection report for a bridge will be prepared by the inspector during examination of the bridge at the site. The reporting Form BR-86 complete with any special notations thereon comprises the Bridge Inspection Report. Inspection Reports for exceptionally large bridges should also be accompanied with photographs. The report should be sufficiently complete so that it can be ascertained from the information contained thereon whether or not loads currently permitted on the bridge can be allowed to continue to operate over the structure safely until the time of the next scheduled inspection. If possible, the report should be complete enough to aid in the preparation of plans for maintenance work which the inspection discloses to be needed.

CODING THE BRIDGE INSPECTION REPORT FORM (BR-86)

Beginning in January 1, 1990, all information already included on the Bridge Inventory and Appraisal Code Sheets (BR-87) will no longer need to be entered on the Bridge Inspection Report (BR- 86). This includes all "Material" and "Type" codes. This information will appear as "pre-printed" information in an appropriate place on the pre-printed BR-86 form.

When filling out the BR-86 form for the first time due to a new bridge or any bridge which has not previously been "inventoried", the BR-87 inventory form must be filled out and submitted prior to BR-86 inspection form or submitted at the same time.

Any corrections or changes to any pre-printed information on the BR-86 form must be submitted on a revised BR-87 form first.

HEADING

Structure File Number: This number is the key to processing all bridge data. It is the permanent identification number for the entire data file on any particular structure. The number consists of a seven (7) digit numeral which is assigned specifically for that structure by the appropriate control authority. The first two digits of the number is the numeric code for the Ohio county in which the structure is located. It is imperative that this Structure File Number be entered legibly and accurately so that data will be processed to the proper bridge file. (See Bridge Inventory and Appraisal Coding Instructions for details).

In the case of one road bridged over another road, it is important to remember that **only one Structure File Number** can exist for that bridge and there can be **only one Inspection Report** filed for that particular bridge. It is imperative that duplication by two different agencies for the same bridge be avoided.

Bridge Number: The bridge number is made up of three separate parts, which are: A three letter county, township, city or other standardized abbreviation code; the complete route number description; and the unit number which consists of the bridge straight line mileage and any special designation codes for ramps, parallel structures, etc. (See Bridge Inventory and Appraisal Coding Instructions for details.)

Year Built: A four digit inventory item in which the first four digits indicate the year of original construction and the second four digits the latest year of any rehabilitation or major improvements. See Bridge Inventory and Appraisal Coding Guide for further details.

Bridge Type: See Bridge Inventory and Appraisal Coding Guide

Type Service: " "

Feature(s) Intersected: " "

CODING OF INDIVIDUAL ITEMS

This is a physical condition report and therefore all items should be coded based on "as built" condition and should not be coded based on current acceptable standards.

If poor quality construction will result in accelerated deterioration or result in reduced strength of a member, this condition should be noted in the comments and considered in the rating of that item even though it was built that way. An example would be several bolts are missing from a field splice (they were never installed) on a 2 girder bridge.

In order to promote uniformity between bridge inspectors, these guidelines will be used to rate and code the items.

Condition ratings are used to describe the existing, in-place bridge as compared to the as-built condition. Condition codes are properly used when they provide an overall characterization of the general condition of the entire component being rated. Conversely, they are improperly used if they attempt to describe localized or nominally occurring instances of deterioration or disrepair. Correct assignment of a condition code must, therefore, consider both the severity of the deterioration or disrepair and the extent to which it is widespread throughout the component being rated.

The load-carrying capacity will not be used in evaluating condition items. The fact that a bridge was designed for less than current legal loads and may be posted will have no influence upon condition ratings.

Portions of bridges that are being supported or strengthened by temporary members will be rated based on their actual condition; that is, the temporary members are not considered in the rating of the item.

Completed bridges not yet opened to traffic, if rated, will be coded as if open to traffic.

When rating the individual items, it is essential that the Inspector ask the following question:

IS IT FUNCTIONING AS DESIGNED?

All individual item's should be inspected with this question in mind.

The following codes will be used to rate the condition of all items except the Summary Items, the General Appraisal, Live Load Response, Vertical Clearance and Survey.

- 1 Good Condition - No repair required
- 2 Fair Condition - Minor deficiency, item still functioning as designed.
- 3 Poor Condition - Major deficiency, item in need of repair to continue functioning as designed.
- 4 Critical Condition - Item no longer functioning as designed.

The following codes will be used to summarize the condition of all Summary Items and the General Appraisal (Specific descriptions will follow for each Summary item):

- 9 Excellent condition
- 8 Very good condition
- 7 Good condition
- 6 Satisfactory condition
- 5 Fair condition
- 4 Poor condition
- 3 Serious condition
- 2 Critical condition
- 1 "Imminent" failure condition
- 0 Failed condition

The condition coding system used for the Summary Items and the General Appraisal was developed by the Federal Highway Administration and is being used by all agencies across the United States. The 1-4 Individual Item condition code was developed by the State prior to the Federal code.

Summary Items and General Appraisal

Individual Items

1 Good

Summary Items

9 Excellent
8 Very good
7 Good

2 Fair	6 Satisfactory 5 Fair
3 Poor	4 Poor 3 Serious
4 Critical	2 Critical 1 "Imminent" Failure 0 Failed

Exceptions to this correlation should be infrequent. (1%) The Items on the Inspection Report that are highlighted by condition boxes with bold outlines should carry the most weight in determining the Summary Rating for each subsection as well as the General Appraisal. The summary rating is driven by the box with a bold outline with the worst condition in the worst span, with the exception of expansion joints, bearing devices and backwalls.

DECK

The primary function of the bridge deck is to provide a smooth riding surface and to transmit the wheel loads to the supporting members. It also provides a support for curbs, walkways, railings, medians, expansion joints, and provides a surface to transmit drainage off the bridge. There are several deck types, but the majority will consist of reinforced concrete, timber, filled or unfilled steel grid, or corrugated steel.

Concrete decks should be inspected (both bottom and top) for cracking, scaling, spalling, leaching, water saturation, potholing, delamination, and full depth failures. Steel grid decks should be inspected for broken welds, broken grids, section loss, and growth of filled grids from corrosion. Timber decks should be inspected for splitting, crushing, fastener failure, and deterioration from rot.

While expansion devices may cause serious problems, rarely will the condition rating of the deck be reduced because of these devices.

Item 1. Floor

The floor is the primary load carrying member of the deck and should be inspected top and bottom for evidence of leakage, deterioration and structural adequacy. The condition of slab

type structures, prestressed concrete box beams and the top flange of prestressed concrete tee beams, should be coded under this item.

Concrete

1. Minor transverse cracks (spacing 20' or more)
2. Transverse cracks evident on bottom side (spacing 10' to 20'); some could be leaking. Some spalling may be present (1% - 10% of total deck area)
3. Saturated areas on bottom side indicating deck is saturated with chlorides. Some bottom spalling may be present. Saturated areas and spalling not exceeding 30% of total deck area.
4. Saturated areas or bottom spalling exceeding 30%. Evidence that full depth holes are soon to appear.

Timber

1. All boards look good. No deterioration or loose fasteners noted.
2. Some boards/floor clips may be loose. Rotting or deterioration noted on less than 5% of boards.
3. Several boards rotted. Up to 30% of boards noted with decay.
4. Several boards broken, cracked, hanging down. Over 30% of boards rotten, damp, white decay noted.

Item 2. Wearing Surface (Protective System)

The primary function of a wearing surface is to provide a smooth riding surface and to protect the underlying floor. It should be examined for smoothness, cracks, drainage, debris, and signs of deterioration.

1. Minor hairline cracks, minor spalls or delaminations.
2. Cracks 1/16th inch or less. Spalls and/or delaminations present but less than 15% of total deck area or asphalt patches less than 3% of total deck area and still providing a smooth riding surface.

3. Cracks greater than 1/16th inch. Spalls and delaminations between 15% and 30% of total deck area or asphalt patches greater than 3%, or causing a rough riding surface.
4. Major cracking. Spalls and delaminations greater than 30% of total deck area or asphalt patches 6% or more of total deck area, and causing a rough riding surface.

Item 3. Curbs, Sidewalks, Walkways

Curbs, sidewalks and walkways do not normally contribute to the structural strength of the bridge. They are provided mainly for motorist safety and pedestrian convenience and protection. They should be examined for deterioration, security of connections and hazards to pedestrians.

Item 4. Median

The primary function of median is to separate oncoming traffic traveling in the opposite direction. It may be level or raised and may or may not have barrier guardrails. It may be closed or have an open expansion or construction joint. Examine for deterioration, damage and security of connection of the guardrail.

Item 5. Railing

Both pedestrians and vehicular railings should be examined for deterioration, damage, security of connections.

1. No evidence of damage or loose connections. No repairs necessary. Minor concrete cracking (spacing 10' or more)
2. Minor vehicular damage. Minor rusting of system. Cracking with efflorescence (spacing less than 10') or minor spalling.
3. Noticeable deterioration of concrete; several posts loose or bent; post anchors deteriorated.
4. Portions of railing missing or damaged beyond repair.

Item 6. Drainage

Effective drainage is essential for the proper maintenance of a bridge. Examine the drainage system for clogging, ponding, vegetation and adequacy. All structures with deck items require a rating for drainage. Condition of metal drip strips will be considered in rating the drainage item.

Item 7. Expansion Joints

Expansion joints provide for the expansion and contraction of the bridge superstructure. Examine carefully for proper opening, anchorage, and deterioration. Also check beam-to-backwall clearances. Condition of sealed joints or 1" compression seals should be noted but not given a condition rating.

- 1 All expansion joints open and functioning as designed. Dirt or other obstructions in joints. Minor leakage onto Superstructure.
- 2 Minor damage to joints. Minor damage to vertical extensions. Major leakage onto the ends of beams.
- 3 Expansion joints nearly closed (less than 1/2" opening).
- 4 Expansion joint tightly closed or beams touching backwall. Not functioning as designed.

Item 8. Deck Summary

The condition of curbs, sidewalks, parapets, bridge rail, and scuppers should be noted on the inspection form. However, their condition will not be considered in the overall deck evaluation.

In arriving at the condition rating for the deck, the condition of the worst span of the deck will dictate the deck rating. Comprehensive rehabilitation of the deck will normally restore the deck element to a rating of 7 or possibly an 8.

The following descriptive codes will be used as a guide in arriving at a Deck Summary:

CONCRETE BRIDGE DECK

Code	Description
9	No Obvious Deficiencies Top Side (Bare Concrete): -no spalls -no surface scaling -no obvious cracks -no delaminations Bottom Side: -no spalls -no obvious cracks

- no damp areas
 - no efflorescence
- 8 Minor Deficiencies
- Top Side (Bare Concrete):
- minor scaling (less than 1/4" deep over 5% of deck surface)
 - a few hairline cracks
 - no delaminations
- Bottom Side:
- minor transverse cracking (cracks > 25' spacing)
 - no dampness
 - no leakage
 - no spalling
- 7 Minor Deficiencies
- Top Side:
- minor scaling (less than 1/4" deep over no more than 10% of deck surface)
 - some minor delaminations not cracked or broken out yet
 - some obvious transverse cracks
- Bottom Side:
- several obvious transverse cracks
 - some minor leakage through cracks
 - minor efflorescence
 - saturated areas of concrete less than 1% of deck area
 - no spalling
 - Excessive leakage of Ex. Jt. causing accelerated deterioration of steel or concrete
- 6 Fair Condition
- Top Side:
- 20% or more scaling (1/2" or less)
 - delaminations noted by sounding (10% broken out)
 - obvious transverse cracks and/or map cracking
 - Ex. Jt. nearly closed (less than 1/2 " opening) or beams nearly touching backwall
- Bottom Side:
- obvious transverse cracks (spacing 15' - 20') and/or map cracking
 - some leakage through cracks
 - efflorescence noted at majority of cracks
 - damp or dark areas 5% or more of deck area

- 1% to 5% spalling (not including edges)
- 5 **Generally Fair Condition**
 - Top Side:
 - 30% scaling
 - obvious delaminations and/or surface patches over 20% of wearing surface
 - obvious transverse cracks and/or map cracking
 - Ex. Jt. tightly closed or beams touching backwall
 - Bottom Side:
 - obvious transverse cracks (spacing 10' - 15') and/or map cracking
 - considerable leakage through cracks
 - efflorescence noted at majority of cracks
 - damp or dark areas 10% or more of deck area
 - 5% to 10% spalling (not including edges)
- 4 **Marginal Condition**
 - Top Side:
 - obvious delaminations and/or surface patches over at least 25% of deck area
 - steel plates covering full depth holes
 - Bottom Side:
 - full depth holes visible
 - much cracking and white efflorescence with 4" stalactites
 - additional dark and damp areas over at least 30% of deck bottom indicates deck should be replaced
 - considerable bottom delaminations
 - 10% to 20% spalling (not including edges)
- 3 **Poor Condition**
 - Top Side:
 - obvious delaminations and/or patches over 40% of wearing surface area
 - very irregular surface causing bridge vibration under live load
 - reinforcing steel exposed in holes at several locations
 - steel plate covering full depth hole
 - Bottom Side:
 - damp or dark areas over at least 50% of floor
 - many cracks with leakage and efflorescence including 6" stalactites
 - some full depth patches have been made
 - conditions indicate deck should be replaced
 - considerable spalling of deck bottom
 - 20% to 30% spalling (not including edges)
- 2 **Critical Condition**

Top Side:

- considerable delaminations
- steel plates covering full depth holes

Bottom Side:

- full depth holes visible
- much cracking and white efflorescence with 8" stalactites
- additional dark and damp areas over at least 50% of deck bottom indicates deck should be replaced
- considerable bottom delaminations

1 Critical Condition - Bridge Closed**Top & Bottom Side:**

- several full depth holes through deck
- holes could be repaired to put bridge back in service, but evidence on bottom of deck indicates additional holes are imminent

0 Critical Condition - Bridge Closed:**Top & Bottom Side:**

- deck collapsed
- full depth holes throughout deck

STEEL BRIDGE DECKS

Code	Description
9	No noticeable or noteworthy deficiencies which affect the condition of the deck.
8	Tightly secured to floor system with no rust.
7	Loose at some connections with minor rusting. A few cracked welds and/or broken grids.
6	Considerable rusting with indications of initial section loss. Loose at many locations. Some cracked welds and/or broken grids.
5	Heavy rusting with areas of section loss. Loose at numerous locations. Numerous cracked welds and/or broken grids.
4	Heavy rusting resulting in considerable section loss and some holes through deck. Majority of welds cracked and/or grids broken.

- 3 This rating will apply if severe or critical signs of structural distress are visible.
- 2 Many holes through deck.
- 1 Bridge closed. Correction action may put back in light service.
- 0 Bridge closed. Replacement necessary.

TIMBER BRIDGE DECKS

Code Description

- 9 No noticeable or noteworthy deficiencies which affect the condition of the deck.
- 8 No crushing, rotting, or splitting. Tightly secured to floor system.
- 7 Minor cracking or splitting with a few loose boards/clips.
- 6 A number of rotted or crushed boards in need of replacement. Many boards cracked or split. Many loose boards/clips.
- 5 Numerous boards cracked, split, rotted, or crushed and in need of replacement. Majority of boards/clips are loose.
- 4 Majority of the boards are rotted, crushed, and/or split; necessitating the replacement of the entire deck.
- 3 This rating will apply if severe or critical signs of structural distress are visible.
- 2 Advanced deterioration with partial deck failure.
- 1 Bridge closed. Corrective action may be put back in light service.
- 0 Bridge closed. Replacement necessary.

SUPERSTRUCTURE

The superstructure is the entire portion of a bridge above the abutment and pier seats, excluding the deck. The superstructure transmits the deck loads to the substructure. The superstructure and the substructure are generally the two most important aspects of the bridge.

The inspector should visually inspect all fracture critical structural members of the bridge within an "arm's-reach" distance. This will require access so that all fatigue prone connections can be inspected within arm's reach. Any cracks discovered and/or suspected as a result of this "hands-on" visual inspection will be documented and will be further defined with the use of dye penetrant, magnetic particle or ultrasonic devices.

Any steel structure with lower lateral bracing, pins and hangers, transverse floor beams and stringers, or any unusual connection details will be carefully inspected for cracks, poorly designed details, or poorly fabricated details.

Any observed section loss on members which are normally analyzed to determine safe load capacity of the bridge, will be measured and documented sufficiently to allow for subsequent reanalysis of the structure.

All pinned connections should be carefully inspected by visual means, within arm's-reach for loss of section, frozen conditions due to pack-rust, and cracks. Non-destructive testing generally does not lend itself to detecting hidden defects in pinned connections, nor is dismantling of the connection considered to be a part of routine annual inspections.

Item 9. Alignment

The superstructure should be examined for any discontinuities in the vertical or horizontal alignment due to settling, shifting, accident damage, etc. All bridges with Superstructure items require a rating for Superstructure Alignment.

Item 10. Beams/Girders or Concrete Slabs

Longitudinal members transferring deck or floor system loads directly to substructure. Examine carefully for deterioration (particularly loss of member cross sectional area), loose connections, cracks or deformations due to overloading and damage (collision or flood). Indicate on report if beams are weathering steel or galvanized steel (not in coding boxes).

If bridge is made up of only 2 or 3 beams, deterioration on any one beam is significant. If bridge consists of multiple beams, deterioration of exterior beams (for example) is generally not significant and should not cause the entire bridge to be rated lower, based on the condition of the two worst beams.

Deterioration of the edge of a slab (closer than 2 feet to the guardrail face) is generally not significant and should not cause the entire bridge to be rated down. Conversely, slabs with transverse spalls exposing more than a third of the re-bars should be considered in poor condition. (Common at midspan and at abutments) District 1.

The concrete Tee beam is a deck and beam system formed in a T-shape. The beams and deck slab act integrally to increase strength and allow for greater spans. Check beam ends for shear cracks. These will occur on the web and project up from the supports diagonally toward midspan. Check at midspan for flexure cracks due to positive moment. Check for exposed tension reinforcement and document section loss on exposed bars. Deterioration of beams should not lower the floor condition rating, but deterioration of the deck should be considered in the beam condition rating and the superstructure summary.

Item 11. Diaphragms or Cross frames

Secondary members in beam and girder bridges placed to distribute stresses and improve rigidity. Examine for condition and security of connections. Fatigue prone connections should be closely inspected and reported. This item should not be based solely on the condition of the end cross frames.

Floor System (Items 12, 13, 14)

NOTE: In general, Items 12, 20, 21, 22 and 23 can be considered secondary structural members and although their failure should receive immediate attention, an individual member failure will not render the structure unsafe.

A system of joists and floor beams which transfers the deck load to the main girders or trusses. The joists are sometimes omitted on short panel lengths in which case the floor itself spans between floor beams. Check all members for loss of section, crushing, cracking and security of connection.

All built-in notches at the ends of floor beams and joists will be carefully inspected for fatigue cracking.

Item 12. Joists/Stringers

The joists span between floor beams and provide the primary support for the deck system. The deck loading is transmitted to the joists and through the joists to the floor beams and then to the truss or girder. The condition of exterior joists should not normally dictate the overall condition of this item. Consider all joists in any one span and rate their overall condition.

Item 13. Floor Beams

The transverse members which support the joists or floor and transmit the loads to the main longitudinal girders or trusses.

Item 14. Floor Beam Connections

The end connections or hangers attaching the floor beams to the trusses or main girders are particularly critical where they are exposed to moisture and de-icing chemicals. Check for loose or broken connections and loss of section.

Items 15 - 23

Generally, these Items pertain only to truss type bridges and should only be coded when inspecting a truss bridge.

Remember cracks are considerably more significant in tension members than compression members. Particular attention should be given to the connections of Items 15-23. Check the integrity of all bolts, nuts, rivets, welds, etc.

Item 15. Verticals

Vertical members extending between top and bottom chords which will resist either tension or compression stresses depending on the truss configuration. Most verticals are also main structural members and their failure would usually be critical and render the truss unsafe.

Item 16. Diagonals

The diagonal members extend between successive top and bottom chords and will either resist tension or compression depending on the truss configuration. Most diagonals are also main structural members and their failure would be extremely critical and render the truss unsafe.

Item 17. End Posts

The end compression member of a truss, either vertical or inclined, extending between chords and functioning to transmit the truss end reaction to the bearings.

Item 18. Top Chord

The upper longitudinal member extending the full length of the truss, (from end post to end post). For a simple span, the top chord is designed to always be in compression. Failure of this chord will render the truss unsafe.

Item 19. Lower Chord

The lower longitudinal member extending the full length of the truss. For a simple span, the lower chord is designed to always be in tension. Failure of this chord will render the truss unsafe.

Bracing

The secondary system of members which distributes loads, stabilizes the bridge against torsional and wind loadings, prevents buckling of compression chords, and integrates the separate main member systems. Check all members for condition, alignment, collision damage, and security of connection.

Item 20. Lower Lateral Bracing

The bottom lateral braces lie in the plane of the bottom chord, or bottom girder flange, and provide lateral stability and resistance to wind stresses.

NOTE: In general, Items 12, 13, 20, 21, 22 and 23 can be considered secondary structural members and although their failure should receive immediate attention, an individual member failure will not render the structure unsafe.

Item 21. Top Lateral Bracing

The top lateral braces lie in the plane of the top chord and provide lateral stability between the two trusses and resistance to wind stresses.

Item 22. Sway Bracing

Sway braces are secondary structural members spanning between the trusses at interior panel points which provide lateral stability and shear transfer between trusses. In the case of low or pony trusses the sway bracing may take the form of knee bracing on the outside of the trusses.

Item 23. Portals

A heavy sway frame which is found overhead at the ends of a thru truss and provides lateral stability and shear transfer between trusses.

Item 24. Bearing Devices

Bearing devices transmit the superstructure load to the substructure. They also provide for longitudinal movement due to expansion and contraction and rotational movement due to deflection. The bridge bearings are vitally important to the functioning of the structure. If they are not kept in good working order, stresses may be induced into the structure that will shorten the usable life of the bridge. Check all components of bearings for deterioration, movement, alignment, contact, security of connections and lubrication where necessary. Generally, bridges have both fixed and expansion bearing devices. Code the condition of the expansion bearing devices.

Item 25. Arch

In general, any structure having throughout its length a curved shape. The curve may be elliptical, circular, parabolic or a combination of shapes. The most common types are the Filled Spandrel Arch, Open Spandrel Arch, Open Spandrel Ribbed Arch and Thru Arch. These are generally constructed of concrete or stone and sometimes of steel. Check all members for deterioration, alignment and signs of failure.

Item 26. Arch Columns or Hangers

The vertical members which bear on or hang from the arch and support the superstructure.

Item 27. Spandrel Walls

A wall built upon an arch to function as a retaining wall for the roadway in a spandrel filled structure; but, when the spandrel is not filled, to support the floor system and its loads.

For Suspension and Movable Bridges See The Rear of This Manual

Item 28. Protective Coating System (PCS)

The Protective Coating System (PCS) consist of the primary means which the superstructure (beams) are protected from the elements. It is imperative that the condition of the protective film be thoroughly inspected.

Painting/Galvanizing/Metalizing/588 Weathering steel/Concrete Sealers shall be rated in this section. For painted steel structures, inspector should note type of paint and year painted stenciled on the bridge ends and compare to pre-printed information on BR-86. Changes should be noted and reported on the Inventory Form after returning to Office. Do not rate any PCS on Substructure items or Deck items. However, if any of the items are in need of recoating the inspector is to make note of it in the appropriate space.

These guidelines are intended to be used to access the coating condition during the inspection as well as upon project completion.

Painted Steel Surfaces

Workmanship Inspection:

Surface preparation must be properly done as specified prior to paint application and should be rated as workmanship conditions. Application of the primer, intermediate, and finish coatings can affect the overall quality of the paint system.

Workmanship inspection areas should include but are not limited to:

- Incomplete removal of mill scale or surface corrosion in pitted steel members
- Areas not receiving paint
- Hard-to-reach areas that may have been missed during painting. (Top of cross frames, inside truss members, behind end dams, etc.)
- Paint Adhesion between coats. Peeling of finish coat
- Grit, from the abrasive cleaning process, is in the paint film or left on the steel members
- Paint thickness applied (total paint thickness should be between 8.5 to 24.5 mills when spot checking the OZEU paint system)

Degradation Inspection:

The degree of coating failure must be assessed during the inspection. Coating failure is measured as a percentage of the total surface area. Percentage guidelines are given in the condition scale. Percentage of paint failures/rust should be noted in the remarks space.

Typically a painting project should not significantly impact the structural steel condition rating if section losses and pitting are present.

Paint failures should include but are not limited to:

- Checking, cracking, wrinkling, and alligation
- Blistering caused by painted over oil, grease, rust
- Pinpoint rusting
- Peeling paint
- Chalking
- Peeling, cracking, or separation of any caulking

Concrete superstructures:

The coding guidelines will be used when rating the concrete superstructures with a protective coating system of Epoxy - Urethane sealers or Non-epoxy sealer. Use only the areas receiving a coating system to calculate the percentage failed. Rating of the PCS is similar to painted structures.

Epoxy - Urethane sealers or Non-epoxy sealer failures should include but are not limited to:

- Peeling
- Chalking
- Flaking

Concrete structures should be spot tested with a putty knife to verify adhesion conditions of the PCS to the substrate.

Inspection of Weathering Steel:

The inspection of weathering steel bridges differs from that of painted steel bridge. In that the entire surface area of weathering steel is covered in rust. The inspector must distinguish between a protective and non-protective oxide coating. Slight variations in color and texture are important indicators of non-protective coating requiring close inspection. Inspector shall note any section loss associated with coating failure in the appropriate item. (Ex. Item 10-Beams, Item 12-Joist/Stringers)

The oxide film must be tested by tapping or by vigorously wire brushing to determine whether the film is adhering to the substrate. The oxide film texture may debond in the form of granules, flakes, or laminar sheets. Physical and visual means are used in conjunction to accurately determine the condition of the oxide film.

New weathering steel require 3 to 5 years to stabilize. An inspector should keep in mind the year built when evaluating the oxide film. The interior surfaces are likely to exhibit the same color of the exterior beams, but sheltered from the wind and rain the initial dusty surface is not sweep clean. Thus becoming embedded and leaving a coarse finish.

Workmanship issues shall include exterior surface and bottom flanges of all fascia beams or girders that are to be left unpainted to remove all traces of asphalt cement, oil, grease, diesel fuel or petroleum deposits, concrete, and other contaminants. The fascia beams shall be free of mill scale.

Condition ratings for weathering steel shall use the visual color table and the texture table below to determine failed areas. The failed areas shall be applied to the condition ratings table. Bridges with a combination of painted beam ends or fascia beams shall rate each portion appropriately and combine the failed areas for the total area.

Visual Color Table for Weathering Steel		
Color	Film Stage	Condition
Yellow-Orange	Initial stage of exposure	Acceptable
Light Brown	Early stage of exposure	Acceptable
Chocolate brown to	Development of protective oxide	Acceptable

purple brown		
Black	Non-protective oxide	Failed

Texture Table for Weathering Steel		
Texture	Surface Stage	Condition
Tightly adherent, capable of withstanding hammering of vigorous wire brushing	Protective oxide film	Acceptable
Dusty	Early stage of exposure	Acceptable
Granular	Possible development of non-protective oxide	Acceptable
Small flakes, 1/4" diameter	Non-protective oxide	Failed
Large flakes, 1/2" diameter	Non-protective oxide	Failed
Laminar sheets of nodules	Non-protective oxide, sever corrosion	Failed

Critical structural

Critical structural member or areas such as pin and hanger connections, steel pier caps, or similar fracture critical members may govern the paint rating. In such cases use the examples in the table below to assess the paint condition. The inspector shall note on the inspection report form which item governed the condition rating.

Hinges

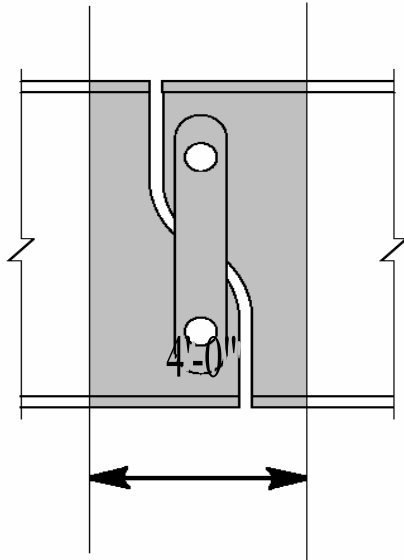

2'-0" on each side of the center shall be considered as the total area in the condition rating guide lines

Steel Pier Caps

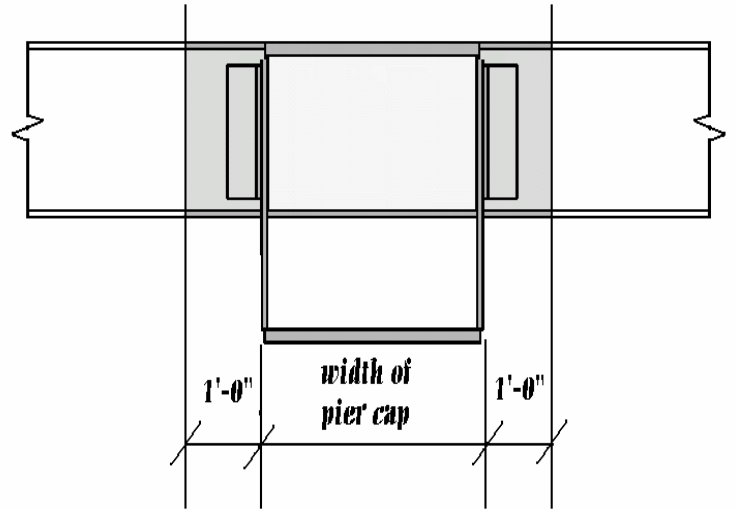

The area of the pier cap plus 1'-0" on each side of the flange edges shall be considered as the total area in the condition rating guide lines

Condition Scale - Item 28. Protective Coating System (PCS)

Scale	Condition Statement
9	There is no evidence of corrosion; the protective coating system (PCS) is sound, fully intact, and functioning as intended to protect the metal or concrete surfaces. No workmanship related issues.

8	<p>Less than 1% of total surface area of the protective coating system is failed. Isolated light surface or freckled rusting along flange edges, cross frame members, end cross frames, bearings, phase or lap marks, or at bolted splices. Isolated chalking or fading or other early evidence of paint system distress.</p> <p>Isolated workmanship issues (painted surfaces only), surface defects less than 5% of total surface area. Workmanship defects include painted over grit, rust, mill scale, heavy paint drips, mud cracking in paint, or other related workmanship issues. No finish coat separation from intermediate coat.</p>
7	<p>Greater than 1% and less than 5% of the total protective coating system is failed. Light surface rusting along flange edges, cross frame members, end cross frames, bearings, phase or lap marks, or at bolted splices.</p> <p>Multiple workmanship issues (painted surfaces only), surface defects less than 10% of total surface area. Workmanship defects include painted over old paint, grit, rust, mill scale, heavy paint drips, mud cracking in paint, or other related workmanship issues. Finish coat separation from intermediate coat less than 10%. Chalking or fading or other early evidence of paint system distress</p> <p>Candidate for zone painting (outside fascia beams or beam ends near joints)</p>
6	<p>Greater than 5% and less than 10% of the total protective coating system is failed. Surface or freckled rust is prevalent throughout. The paint system is no longer effective at beam ends beneath joints. There may be exposed metal but there is no corrosion, which is causing loss of section. Peeling, cracking, or separation of any caulking material</p> <p>Workmanship issues (painted surfaces only), surface defects less than 15% of total surface area. Workmanship defects include painted over old paint, grit, rust, mill scale, heavy paint drips, mud cracking in paint, or other related workmanship issues. Finish coat separation from intermediate coat greater than 10%.</p> <p>Candidate for zone painting (outside fascia beams or beam ends near joints)</p>

5	<p>Greater than 10% and less than 15% of the total protective coating system is failed. Surface or freckled rust is prevalent. The paint system is no longer effective at steel bridge bearings, beam ends near joints at abutments and piers and along outside face of fascia beams. There is exposed metal with active corrosion causing light loss of section or pitting, typically less than 1/8". Peeling, cracking, or separation of any caulking material with rust staining.</p> <p>Workmanship issues (painted surfaces only), surface defects greater than 20% of total surface area.</p> <p>Candidate for zone painting (outside fascia beams and beam ends near joints)</p>
4	<p>Greater than 15% and less than 20% of the total protective coating system is failed. Surface or freckled rust is prevalent. The PCS system is no longer effective. There is exposed steel throughout the structure with active corrosion. Failure of caulking on crevice corrosion.</p> <p>Old paint system was painted over.</p> <p>Candidate for total recoating.</p>
3	<p>Greater than 20% and less than 30% of the total protective coating system is failed. The paint system is no longer effective. There is exposed steel throughout the structure with active corrosion.</p> <p>Candidate for total recoating.</p>
2	<p>Greater than 30% and less than 40% of the total protective coating system is failed.</p> <p>Candidate for total recoating.</p>
1	<p>Greater than 40% and less than 50% of the total protective coating system is failed.</p> <p>Should be programmed for total recoating, or structure replacement</p>
0	<p>Greater than 50% of the protective coating system has failed. Corrosion has caused section losses.</p> <p>Should be programmed for total recoating, or structure replacement</p>

NOTE: The inspector needs to remember leaking joints above critical area can be recorded in the appropriate items better to suited account for functionality, deterioration, and other safety related concerns.

Item 29. Pins, Hangers, Hinges

Inspect all pins, pins and hangers, and seated hinges for evidence of freedom of movement. Check for pack rust which would limit movement and section loss around support areas. Check alignment of the adjoining members. Be particularly cognizant of pack rust developing between the hangers and the beam/girder webs. Also look for evidence of pin and/or hanger wear and loosening of keeper plates or nuts.

The condition of pins/hangers and seated hinges on twin girder structures is particularly important. Multiple girder bridges have built-in redundancy which make them less prone to catastrophic failure.

Pins with exposed ends can be periodically checked using ultrasonic equipment. Consideration should also be given to applying motor oil to the pins and hangers during each inspection.

Please refer to Bridge Inventory and Appraisal Coding Guide Item 28, Hinges, for type codes.

This Item can also be used to code the condition of pins in trusses

Code	Condition
-------------	------------------

- | | |
|----|--|
| 1. | Appears to be functioning as designed |
| 2. | Minor rusting, still functioning |
| 3. | Significant rusting, still evidence of movement |
| 4. | Significant rusting, member is failed or completely inoperative due to pack rust |

Item 30. Fatigue Prone Connections

This Item pertains mainly to welded steel members subjected to bending. Fatigue cracking is generally not a problem on riveted structures.

Closely observe all connections or other appurtenances which may cause secondary stresses or out-of-plane-bending which could lead to partial or complete failure of the bridge.

On welded structures look closely at all main member welded splices and all other welded connections; especially in tension zones. Twin girder structures are obviously most critical in this respect; however, failure due to stress concentrations in a multiple girder bridge can lead to major traffic disruptions until repairs can be made.

Pay particular attention to:

- (1) Lower lateral connections (gussets) to main members in the mid-span or positive moment areas.
- (2) Floor beam connections (stiffener to web welds) near and over the piers (negative moment areas). Generally speaking, bolted field splices are indicators of zero moment or moment change areas, i.e., positive moment occurs from mid span to bolted splices; negative moment occurs from piers to bolted splices.
- (3) The ends of welded cover plates on the bottom flange in mid span.
- (4) Connections where beams frame into steel pier caps.

In all of the above look for:

- (a) Obvious cracks
- (b) Paint peeling or checking

Dye penetrant should be used to check all suspicious areas, especially on twin girder bridges.

Please refer to Bridge Inventory and Appraisal Coding Guide, Item 28 A, Fracture Critical Bridge for type codes.

Code	Condition
-------------	------------------

- | | |
|----|---|
| 1. | No distress apparent |
| 2. | Paint discoloration or checking |
| 3. | Suspicious areas, minor cracking, cracks have not progressed since last inspection. |
| 4. | Cracks obvious, notify Engineer at once to determine if bridge should be closed. |

Refer to "Inspection of Fracture Critical Bridge Members Manual" for further details. Welded cover plates on multiple beam bridges should be rated in this item. Any defects on these welds should be noted.

Do not rate this item for cross frame connections.

Item 31. Live Load Response

Observe the bridge from beneath while heavy vehicles (trucks) are crossing so as to ascertain excessive deflection, vibration, unusual noises and other indications of structure defects.

Condition Code

- E Excessive
- S Satisfactory (normal)

Item 32. Superstructure Summary

This item includes the physical condition of all structural members, and bearings, for signs of distress which may include cracking, deterioration, section loss, and malfunction and misalignment of bearings.

In most cases, the Superstructure rating should not be influenced by the deck rating. Exceptions to this would be composite or integral decks as noted in the Deck Summary.

While bearing devices may cause serious problems, rarely will the condition rating of the superstructure be reduced because of bearings. Bearings for trusses and twin girder bridges should be given full consideration in the superstructure rating.

The inspector should determine if the bridge is fracture critical or has fracture critical components. Fracture critical components should receive careful attention because failure could lead to collapse of a span or the bridge. In-Depth inspections should be scheduled when signs of distress are noted and in some cases partial disassembly may be required to ascertain the condition.

The condition of the paint system or the wearing surface/deck protection will not influence the rating of the superstructure. In arriving at the Superstructure rating including Superstructures with integral decks, the condition of the worst **span** will dictate the superstructure rating.

Comprehensive rehabilitation of the Superstructure will normally restore the Superstructure to a rating of 8.

Rate and code the conditions in accordance with the previously described general condition ratings and the following descriptive codes which will be used as a guide in evaluating the Superstructure condition.

Two sets of descriptive codes will be used to evaluate this item: (1) the codes applicable to all Superstructures which are not tied to a specific type of material and (2) the codes applicable specifically to concrete, steel or timber Superstructures. The lowest of the codes obtained will be used.

APPLICABLE TO ALL SUPERSTRUCTURES

Code	Description
9	No noticeable or noteworthy deficiencies which affect the condition of the superstructure.
8	Problems noted, deficiencies
7	Some minor problems. No-flexural cracks no rust stain
6	Structural elements show some minor deterioration. Non-structural cracks. No rust stains.
5	All primary structural elements are sound but may have minor section loss, cracking, spalling. Flexural cracks with no rust stains.
4	Advanced section loss, deterioration, spalling. Severe rust stains with extensive spalls and exposed reinforcement.
3	Loss of section, deterioration. Spalling has seriously affected primary structural elements local failures are possible, shear cracks in concrete may be present. Extensive spalling with exposed reinforced with section loss. Flexural or shear cracks.
2	Some permanent deformation of a main support member.
1	Bridge closed. Corrective action may put back in light service.
0	Bridge closed. Replacement required.

CONCRETE SUPERSTRUCTURE

Code	Description
9	No noticeable or noteworthy deficiencies which affect the condition of the superstructure.
8	Minor deficiencies
7	Some minor problems. Minor spalls or cracks.
6	Structural elements show some minor deterioration. Moderate spalls (no section loss of reinforcement).
5	All primary structural elements are sound but may have minor section loss, cracking, spalling. Moderate spalls with rust stains and exposed reinforcement.

- 4 Advanced section loss, deterioration, spalling. Extensive spalls and exposed reinforcement.
- 3 Loss of section, deterioration, spalling has seriously affected primary structural elements local failures are possible. Shear cracks in concrete may be present. Extensive spalling with exposed reinforcement with section loss. Flexural or shear cracks.
- 2 Concrete disintegrated around reinforcing steel with loss of bond.
- 1 Bridge closed. Corrective action may put back in light service.
- 0 Bridge closed. Replacement necessary.

PRESTRESSED CONCRETE SUPERSTRUCTURE

Code	Description
9	No noticeable or noteworthy deficiencies which affect the condition of the superstructure.
8	Minor problems noted. Minor deficiencies.
7	Minor cracking of beams spalling along edge.
6	Minor cracking. One or two strands exposed. Some joints between beams leaking with subsequent spalling.
5	Some beam end deterioration. 5 or 6 joints between beams leaking, spalling with 5 or 6 strands exposed. No broken strands.
4	Beam end deterioration. Many joints leaking. Spalling concrete. 10-20% strands exposed. 1 or 2 broken and hanging down.
3	25%- 50% strands exposed. 3-5 broken and hanging down.
2	Bridge critical. 50% - 60% of strands exposed. At least 5 strands broken and hanging down.
1	Bridge closed. Many exposed strands. Several beams have noticeable sag.
0	Bridge closed. Nearly all strands are exposed. Many broken strands hanging down. Beams are sagging.

STEEL BEAM SUPERSTRUCTURE

Code	Description
9	No noteworthy deficiencies.

- 8 Minor surface rusting (5% or less) under expansion joints
- 7 Minor surface rusting (5% or less) on all beams; around bearing devices; no section loss.
- 6 Surface rusting (10% or less) on all beams/bearing devices. Initial section loss (minor pitting).
- 5 Surface rusting (15% or less) on all beams. Some areas of heavy pitting (no perforations) under expansion joints. Fatigue or out-of-plane bending cracks present in non-critical areas.
- 4 Minor perforations through web under expansion joints. Heavy pitting on flanges. 5-10% section loss (avg.) all beams. Fatigue or out-of-plane bending cracks present in major structural elements. Hangers frozen due to corrosion.
- 3 Extensive perforations through fascia beam webs. Minor perforations through all beams. 10-20% section loss (avg.) all beams.
- 2 Extensive rust-through on all beams. Extensive section loss on bottom flanges. 20%-30% section loss (avg.) on all beams. Bridge should be load posted.
- 1 Extensive rust-through on all beams. Bridge is closed. Possibility of making welded repairs and/or selective member replacement to re-open bridge.
- 0 Extensive rust-through on all beams. Bridge is closed. Cannot be repaired.

STEEL TRUSS SUPERSTRUCTURE

Code Description

- 9 No noteworthy deficiencies
- 8 Minor surface rusting; no section loss.
- 7 Minor rusting; flaking paint.
- 6 Minor pitting on fascia stringers, bottom chord and bearing devices.
- 5 Considerable surface rusting of fascia stringers, bottom chord, bearing devices (less than 5% section loss).
- 4 Considerable rusting on all stringers; minor perforations in fascia stringers; 5%-10% section loss on lower chord/floor beam connections. Pack rust at lower chord connections.
- 3 Extensive perforations in fascia stringers. Minor perforations through all stringers. 10%-20% section loss on lower chord/floor beam connections. All truss members (verticals, diagonals, end posts) have extensive

- pitting (no perforations) in splash zone area. Section loss at lower chord connections.
- 2 Extensive perforations in all stringers. 20%-30% section loss in lower chord/floor beam connections. Perforations in other truss members in splash zone area (verticals, diagonals, end posts). Bridge should be load reduced.
 - 1 Extensive rust through in all stringers, floor beams, floor beam connections, verticals, diagonals, end posts. Lower chord rusted through or broken. Bridge is closed. Possibility of making welded repairs and/or selective member replacement in order to re-open bridge.
 - 0 Extensive rust through of many members. Bridge is closed. Cannot be repaired.

TIMBER SUPERSTRUCTURE

Code	Description
9	No noticeable or noteworthy deficiencies which affect the condition of the superstructure.
8	Very good condition. No deterioration.
7	Timber is dry but has minor checking
6	Timber shows minor deterioration. Less than 2% moist timber with moderate checking.
5	Timber sound, may have minor section loss cracking. Less than 5% moist or 2% decayed timber with moderate checking.
4	Advanced deterioration. Greater than 5% decayed timber or heavily checked.
3	Severe decay, cracking, splitting, or crushing of beams or stringers.
2	Advanced deterioration of timber. Unless closely monitored it may be necessary to close the bridge until corrective action is taken. Deck structural capacity inadequate.
1	Bridge closed. Corrective action may put back in light service.
0	Bridge closed. Replacement necessary.

MASONRY SUPERSTRUCTURE

Code	Description
------	-------------

- 9 No noticeable or noteworthy deficiencies which affect the condition of the superstructure.
- 8 Very good condition. Minor deficiencies.
- 7 Some minor problems. Stones intact, isolated locations of shallow mortar deterioration .
- 6 Stones show some minor deterioration. Stones intact, extensive areas of shallow mortar deterioration.
- 5 Stone mostly sound but may have minor section loss spalling. Minor surface cracking of stones, isolated locations of mortar deterioration.
- 4 Advanced stone loss, deterioration, spalling. Displaced stones, extensive areas of mortar deterioration.
- 3 Deterioration, spalling has seriously affected primary structural elements local failures are possible. Missing stones, extensive areas of missing mortar.
- 2 Several stones displaced or missing. Cracks run through stones. Some settlement. Sag or bulge in shape.
- 1 Several stones have fallen out and more imminent. Significant sag or bulging. Bridge closed.
- 0 Bridge closed. Many stones have fallen out. Sag or bulging indicates bridge is near collapse.

SUBSTRUCTURE

The substructure is that portion of the bridge below the pier and abutment seats, including footers and piling. The substructure transmits the loads and stresses from the deck, superstructure, or other load supporting system, to the ground.

All exposed or readily accessible portions of the substructure will be inspected at close range. Underwater investigation will be done to assure that scour and undermining is not threatening the bridge. This will consist of probing in relatively shallow water and diving in deeper water. Diving inspections will be performed at least once every 5 years on bridges where water depth prohibits visual or probing inspections.

While backwalls may cause serious problems, rarely will the condition rating of the substructure be reduced because of the backwalls. An example of the backwall reducing the summary rating would be if a seriously undermined approach slab which was not adequately supported by a severely deteriorated backwall.

Item 33. Abutments

A substructure supporting the ends of a single span or the extreme ends of a multi-span superstructure and, in general, retaining or supporting the approach embankment. Examine abutments for condition, movement, bulging, cracking, settlement, joint integrity, leakage, and scour.

1. Minor cracks
2. Minor spalls
Small delaminated areas with some white efflorescence.
Stones show minor deterioration.

Extensive areas of shallow mortar deterioration.
3. Noticeable settlement detected by sighting down the railing.
Diagonal or vertical shear crack with displacement.
Large delaminated areas.
Large saturated areas with efflorescence.
Large areas of spalling with loss of section to reinforcing steel.
Stone abutment has noticeable bulge detected by sighting across front of abutment.
Several stones are displaced or missing.
Misalignment of mortar joints.
4. Deterioration or damage is beyond repair.
Abutment is near a state of collapse.
50% or more of abutment has large saturated areas with efflorescence.
Numerous missing stones.

Item 34. Abutment Seats

Check bearing areas for cracking, spalling and other signs of failure. The edges are particularly critical under beams or bearing devices on truss and twin girder bridges.

Dirt and debris should be noted but not considered in rating this item. Most slab bridges do not have abutment seats. Any deterioration in the bearing areas should be noted and considered in the abutment condition rating.

1. Minor cracks.
2. Minor spalls.

- Small unsound areas.
- 3. Spalls on beam seats causing reduced bearing area.
Large unsound areas.
- 4. Deterioration is beyond repair.
Abutment seat is near a state of collapse.
Spalls along most of seat.

Item 35. Piers

A substructure supporting the ends of the spans of a multi-span superstructure at intermediate locations between the abutments. Examine for condition, movement or settlement, and scour. Welded steel pier caps will be very carefully inspected by visual means, within "arms reach", for potential fatigue cracks.

- 1. Minor cracks
- 2. Minor spalls
Small delaminated areas with some white efflorescence.
Minor loss of section of steel piles near flow line.
- 3. Noticeable settlement detected by sighting down the railing.
Vertical shear crack with displacement.
Large delaminated areas.
Large saturated areas with white efflorescence.
Large areas of spalling with loss of section to reinforcing steel.
Major loss of section of steel piles near flow line.
- 4. Deterioration or damage is beyond repair.
Noticeable buckling or misalignment of several steel piles.

Item 36. Pier Seats

The uppermost part of a pier upon which the superstructure rests. Check bearing areas for cracking, spalling and other signs of failure. The edges are particularly critical under beams and bearing devices on truss and twin girder bridges. Most slab bridges do not have pier seats.

- 1. Minor cracks

2. Minor spalls
Small unsound areas
3. Spalls on beam seats causing reduced bearing area.
Large unsound areas
4. Deterioration is beyond repair.

Item 37. Backwall

The topmost portion of an abutment extending above the bridge seat which functions primarily as a retaining wall for the approach embankment. It may also serve as a support for an approach slab. Check backwalls for condition and amount of clearance between beam ends and face of backwall which may indicate abutment movement or pavement pressures.

Semi-integral abutments have a backwall above the construction joint.

- 1 Excellent condition, no repairs needed
- 2 Minor cracks or leakage
- 3 Top of backwall spalled or spalled on face of backwall or some leaning of backwall
- 4 Backwall is broken out from top side to below expansion joint angle on bottom side or backwall is leaning inward and touching beam ends

Item 38. Wingwalls

Extensions of abutments to retain approach embankment. Check for condition and evidence of movement.

Item 39. Fenders and Dolphins

Fenders and dolphins around piers or abutments protect the substructure against collision by vessels. They are designed to absorb the energy of physical contact with the vessel. They are also used to deflect debris and ice. Check for condition, damage and security of connection.

Item 40. Scour

Underwater investigation will be done to assure that scour and undermining is not threatening the bridge. This will consist of probing in relatively shallow water and diving in deeper water. Diving inspections will be performed at least once every 5 years on bridges where water depth prohibits visual or probing inspections. Diving inspections should be performed more frequently

if circumstances warrant it. If a dry year results in normal water depths under 5 feet, the diving inspection could be postponed.

Check all substructure units for evidence of undermining due to scour. This may be done visually if stream is dry or if water is clear and not too deep for waders. This will require probing in deeper areas from a boat or the use of a diver. During high flow, holes can become deeper or fill in temporarily.

This item requires a two part code. The first box will indicate the type of inspection made:

- 1 Visual
- 2 Probing
- 3 Diving

Visual inspection is not advisable for foundations in water not on piling or rock. An exception to this would be a case where clear water is less than 1 foot deep and scour has not occurred in the past.

The second box is the condition:

1. No evidence of scour (past or present). Minor erosion more than 10 feet from abutment or pier.
2. Indication of holes developing around substructure. Portions of the top of the footer may be exposed. Evidence that site has had scour problems, but have been corrected. Deep holes more than 10 feet from abutment or pier. Damage to scour counter measures. Probing indicates soft material in scour hole.
3. A portion of the footing is exposed of an unknown foundation. The bottom of footing is exposed, but on piling or rock. Drilled shaft is exposed, piling is exposed. Major stream erosion behind wingwall that will threaten abutment. Evidence of movement (vertical or rotational) of piers or abutment.
4. Bottom of footing is exposed and not on piling or rock.

Item 41. Slope Protection

Examine slope areas directly under bridge ends for erosion, missing stone, broken concrete, etc. If channel extends all the way to the abutments, there is no slope protection to rate. There is usually no slope protection to rate for walled abutment.

Code	Condition
------	-----------

1. No repairs necessary
2. Minor erosion or cracked (0" - 6" ruts)
3. Significant erosion (6" - 2' ruts)
4. Major erosion, (2' + ruts) footers exposed, concrete riprap collapsing, repairs should be made immediately

Item 42. Substructure Summary

This Item includes the physical condition of piers, abutments, piles, fenders, footings, or other components and conditions as a result of scour or collision.

The Inspector should inspect all substructure elements for visible signs of distress which reduce the capacity of these elements to carry the superstructure and live load. Major problems are cracking, section loss, settlement, and misalignment.

Integral abutment wingwalls will be included to the first construction or expansion joint. For non-integral superstructure and substructure units the substructure will be considered as the portion below the bearings. For structures where the substructure and superstructure are integral, the substructure will be considered as the portion below the superstructure.

The superstructure element will not influence the substructure rating when the superstructure and substructure are integral. For example, the deck or superstructure rating of a slab, concrete T-beam, rigid frame, etc. will not influence the substructure rating even though that portion of the deck or superstructure over the columns may be designed as part of the substructure element.

In arriving at the condition rating for the substructure, the condition of the worst substructure unit will dictate the substructure rating.

Comprehensive rehabilitation of substructure units will normally restore the substructure unit to at least a 7 rating.

Rate and code the conditions in accordance with the previously described general condition ratings and the following additional descriptive codes which will be used as a guide in evaluating the substructure condition.

REINFORCED CONCRETE SUBSTRUCTURE

Code	Description
9	No noticeable or noteworthy deficiencies which affect the condition of the substructure. Insignificant scrape marks caused by drift or collision.

- | | |
|---|--|
| 8 | Minor deficiencies |
| 7 | Some minor problems. Minor cracks |
| 6 | Minor cracking or spalls, minor scour damage. |
| 5 | Minor cracking, spalling. Moderate scour damage and undermining. |
| 4 | Advanced deterioration, spalling, scour. Spalls on beam seats causing reduced bearing area. |
| 3 | Deterioration, spalling or scour have seriously affected piers or abutments. Local failures are possible. Shear cracks in concrete may be present. Heavy scour damage, vertical shear crack, with displacement, requires immediate repair. |
| 2 | Concrete pier cap is spalling with bottom row of reinforcing steel exposed with no bond to the concrete. Top of pier cap is split or concrete column has undergone shear failure. Scour is sufficient that substructure is near state of collapse. Pier has settled. |
| 1 | Bridge closed. Corrective action may put back in light service. |
| 0 | Bridge closed. Replacement necessary. |

MASONRY SUBSTRUCTURE

Code	Description
9	No deficiencies
8	Minor deficiencies
7	Some minor problems. Stones intact, isolated locations of shallow mortar deterioration .
6	Stone shows some minor deterioration. Stones intact, extensive areas of shallow mortar deterioration
5	Stone sound, but may have minor cracking spalling or scour. Minor surface cracking of stones, isolated locations of mortar deterioration.
4	Advanced deterioration, spalling or scour displaced stones, extensive areas of mortar deterioration.
3	Some misalignment of mortar joints. Minor bulging. A few stones missing.
2	Advanced deterioration of stone. Unless closely monitored, it may be necessary to close the bridge until corrective action is taken. Missing stones, extensive areas of missing mortar. Repair required immediately. Significant misalignment of mortar joints. Evidence of settlement and/or bulging.

- 1 Bridge closed. Several stones displaced/missing. Significant bulging/settlement.
- 0 Portions of substructure is collapsed. Bridge is closed.

CULVERT

Culvert type bridges are structures which convey water or form a passageway through an embankment and are designed to support super-imposed loads of earth or other fill material plus a live load. Generally, prefabricated or corrugated metal structures 10' span or greater are considered to be culvert type bridges. Masonry arches with integral spandrel walls, sidewalks and railings will not be coded in this section.

Refer to "Culvert Inspection Manual" for further details.

NOTE: Items will not be coded unless the structure is inventoried as "Culvert Type Structure." The second digit of the Bridge Type should be coded "9" (to indicate a culvert) in the heading of the BR-86 Form.

Item 43. General

Check all culvert type bridges for deterioration, settlement, open joints, plugging, cracks or signs of movement. If culvert has been extended, code the worst condition or the most predominant.

Item 44. Alignment

Check the alignment of the culvert barrel being especially critical of discontinuities between any adjacent culvert segments.

Item 45. Shape

Generally only used for corrugated metal culverts. Inspect the barrel of the culvert for evidence of flattening, buckling, bulging, out-of-roundness and other signs that the shape is not equal to original design. This can best be done by approaching the culvert from the ends and sighting the sides and top. Also check for signs of pavement depression, guardrail movement, gaps between headwalls and pipe barrel. Dimension check should be made for suspect structures.

- 1 Smooth consistent curvature in barrel. No evidence of flattening
- 2 Minor flattening, bulging
- 3 Significant bulging
- 4 Culvert threatening collapse or collapsed

Item 46. Seams

For corrugated metal, multi-plate structures only. All bolted splice seams should be checked for loose or missing bolts, cusping at overlap, and tears or cracks in metal at the bolt lines. This inspection will require a flashlight in most cases.

1. All seams tight
2. Minor seepage around bolts, cusping less than 1/4", minor Cracking around bolts, cracks 1/4" or less in length in only One or two plate sections.
3. Cusping 1/4" or more, cracks less than 1" long in one half of the plates.
4. Cusping 1/2" or more in many locations, cracks more than 1" long around bolts in many locations.

NOTE: Please write in the space provided the size of the gaps or cusps and the number and length of cracks

Item 47. Headwalls or End Walls

Headwalls or endwalls are designed to retain the embankment and prevent the water from undermining the culvert ends. Check all headwalls or endwalls for deterioration, settlement, undercutting and signs of failure.

Item 48. Scour

Check for evidence of scour or undermining around footers and at inlet and outlet of culvert.

- 1 No evidence of scour at either inlet or outlet of culvert.
- 2 Minor scour holes developing at inlet or outlet (12" or less deep). Damage to scour counter measures. Probing indicates soft material in scour hole.
- 3 Significant scour holes developing at inlet or outlet (less than 3' deep). Does not appear to be undermining cutoff walls or headwalls. Major stream erosion behind headwall that threatens to undermine culvert.
- 4 Major scour holes at inlet or outlet (3' or deeper) undermining cutoff walls or headwalls.

Item 50. Culvert Summary**Corrugated Metal Culverts**

Code	Condition
9	New condition
8	Good condition <u>Shape:</u> good, smooth curvature in barrel; span dimension within 10 percent of design <u>Seams and Joints:</u> tight, no openings <u>Metal:</u> - <u>Aluminum:</u> superficial corrosion, slight pitting - <u>Steel:</u> superficial rust, no pitting
7	Generally good condition <u>Shape:</u> generally good, top half of pipe smooth but minor flattening of bottom; span dimension within 10 percent of design <hr/> <u>Seams or Joints:</u> minor joint or seam openings, potential for backfill infiltration <u>Metal:</u> - <u>Aluminum:</u> moderate corrosion, no attack of core alloy - <u>Steel:</u> moderate rust, slight pitting
6	Fair condition <u>Shape:</u> fair, top half has smooth curvature but bottom half has flattened significantly, span dimension within 10 percent of design. <u>Seams or joints:</u> minor cracking at bolts is prevalent in one seam in lower half of pipe. Evidence of backfill infiltration through seams or joints <u>Metal:</u> - <u>Aluminum:</u> significant corrosion, minor attack of core alloy - <u>Steel:</u> fairly heavy rust, moderate pitting
5	Generally fair condition <u>Shape:</u> generally fair, significant distortion at isolated locations in top half and extreme flattening of invert, span dimension within 10 to 15 percent greater than design

Seams or joints: moderate cracking at bolt holes along one seam near bottom of pipe, deflection of pipe caused by backfill infiltration through seams or Joints

Metal:

-Aluminum: significant corrosion, moderate attack of core alloy

-Steel: scattered heavy rust, deep pitting

4 Marginal condition

Shape: marginal significant distortion throughout length of pipe, lower third may be kinked, span dimension within 10 percent to 15 percent greater than design, noticeable dip in guardrail over pipe.

Seams or Joints: Moderate cracking at bolt holes on one seam near top of pipe, deflection caused by loss of backfill through open joints.

Metal:

- Aluminum: extensive corrosion, significant attack of core alloy

- Steel: extensive heavy rust, deep pitting, heavy loss of section, chipping hammer could easily punch a hole thru metal.

3 Poor condition

Shape: poor with extreme deflection at isolated locations, flattening of crown, crown radius 20 to 30 feet, span dimension in excess of 15 percent greater than design

Seams or joints: 3 inch long cracks at bolt holes on one seam

Metal:

- Aluminum: extensive corrosion, attack of core alloy, scattered perforations

- Steel: extensive heavy rust, deep pitting, scattered perforations

2 Critical condition

Shape: critical, extreme distortion and deflection throughout pipe flattening of crown, crown radius over 30 feet, span dimension more than 20 percent greater than design

Seams or joints: plate cracked from bolt to bolt on one seam

Metal:

- Aluminum: extensive perforations due to corrosion

- Steel: extensive perforations due to rust

1 Critical condition

Shape: partially collapsed with crown in reverse curve

Seams or joints: failed

Road: closed to traffic

0 Critical condition

Pipe: totally failed

Road: closed to traffic

Corrugated Metal Pipe Arches

Code Condition

9 New condition

8 Good condition

Shape: good with smooth curvature; span dimension with less than 3 percent greater than design

Joints or seams: good condition

Metal: minor construction defects, protective coatings intact

- Aluminum: superficial corrosion, slight pitting

- Steel: superficial rust, no pitting

7 Generally good condition

Shape: generally good, smooth curvature in top half, bottom flattened but still curved; span dimension within 3 to 5 percent greater than design

Joints or seams: minor joint or seam openings, infiltration of backfill possible

Metal:

- Aluminum: moderate corrosion, no attack of core alloy

- Steel: moderate rust, slight pitting

6 Fair condition

Shape: fair, smooth curvature in top half, bottom flat, span dimension within 5 percent greater than design

Joints or seams: minor cracking all along one seam, minor joint openings with evidence of infiltration

Metal:

- Aluminum: significant corrosion, minor attack of core alloy

- Steel: fairly heavy rust, moderate pitting

5 Generally fair condition

Shape: generally fair, significant distortion in top in one location; bottom has slight reverse curvature in one location

Joints and seams: moderate cracking at bolt holes along a seam in one section, backfill being lost through seam or joint causing slight deflection

Metal:

- Aluminum: significant corrosion, moderate attack of core alloy

- Steel: scattered heavy rust, deep pitting

4 Marginal condition

shape: marginal, significant distortion all along top of arch, bottom has reverse curve; span dimension more than 7 percent greater than design, noticeable dip in guardrail over pipe.

Joints and seams: moderate cracking all along one seam; backfill infiltration causing major deflection

Metal:

- Aluminum: extensive corrosion, significant attack of core alloy

- Steel: extensive heavy rust, deep pitting, heavy loss of section, chipping hammer could easily punch a hole thru metal.

3 Poor condition

Shape: poor, extreme deflection in top arch in one section; bottom has reverse curvature throughout; span dimension more than 7 percent greater than design

Seams: seam cracked 3 in. on each side of bolt holes

Metal:

- Aluminum: extensive corrosion, attack of core alloy, scattered perforations

- Steel: extensive heavy rust, deep pitting, scattered perforations

2 Critical condition

Shape: critical, extreme deflection along top of pipe; span dimension more than 7 percent greater than design

Seams or joints: seam cracked from bolt to bolt down one seam

Metal:

- Aluminum: extensive perforations due to corrosion

- Steel: extensive perforations due to rust

1 Critical condition

Shape: structure partially collapsed

Seams or joints: seam failed

Road: closed to traffic

0 Critical condition

Shape: structure collapsed

Road: closed to traffic

Precast Concrete Culverts**Code Condition**

9 New condition

8 Good condition

Alignment: good, no settlement or misalignment

Joints: tight with no defects apparent

Concrete: no cracking, spalling, or scaling present; surface in good condition

7 Generally good condition

Alignment: generally good; minor misalignment at joints; no settlement

Joints: minor openings, possible infiltration or exfiltration

Concrete: minor hairline cracking at isolated locations; slight spalling or scaling present on invert

6 Fair condition

Alignment: fair, minor misalignment and settlement at isolated locations

Joints: minor backfill infiltration due to slight opening at joints; minor cracking or spalling at joints allowing exfiltration

Concrete: extensive hairline cracks, some with minor delamination or spalling; invert scaling less than 0.25 in. deep or small spalls present

5 Generally fair condition

Alignment: generally fair; minor misalignment or settlement throughout pipe; possible piping

Joints: open and allowing backfill to infiltrate; significant cracking or joint spalling

Concrete: cracking open greater than 0.12 in. with moderate delamination and moderate spalling exposing reinforcing steel at isolated locations; large areas of invert with surface scaling or spalls greater than 0.25 in. deep

4 Marginal condition

Alignment: marginal, significant settlement and misalignment of pipe; evidence of piping, end sections dislocated about to drop off

Joints: differential movement and separation of joints, significant infiltration or exfiltration at joints

Concrete: cracks open more than 0.12 in. with efflorescence and spalling at numerous locations; extensive surface scaling on invert greater than 0.5 in.

3 Poor condition

Alignment: poor with significant ponding of water due to sagging or misalignment of pipes; end section drop off has occurred

Joints: significant openings, dislocated joints in several locations exposing fill material; infiltration or exfiltration causing misalignment of pipe and settlement or depressions in roadway

Concrete: extensive cracking, spalling, and minor slabbing; invert scaling has exposed reinforcing steel

2 Critical condition

Alignment: critical; culvert not functioning due to alignment problems throughout

Concrete: severe slabbing has occurred in culvert wall, invert concrete completely deteriorated in isolated locations

1 Critical condition

Culvert: partially collapsed

Road: closed to traffic

0 Critical condition

Culvert: total failure of culvert and fill

Road: closed to traffic

Cast-in-Place Culverts

Code	Condition
9	New condition

- 8 Good condition
- Alignment: good, no settlement or misalignment
- Joints: tight with no defects apparent
- Concrete: no cracking, spalling, or scaling present; surface in good condition
- Footings: good with no invert scour
- 7 Generally good condition
- Alignment: generally good; minor misalignment at joints; no settlement
- Joints: joint material deteriorated at isolated locations
- Concrete: minor hairline cracking at isolated locations; slight spalling or scaling present on invert or bottom of top slab
- Footings: good with only minor invert scour
- 6 Fair condition
- Alignment: fair, minor misalignment and settlement at isolated locations
- Joints: joint material generally deteriorated, minor separation, possible infiltration or exfiltration; minor cracking or spalling at joints allowing exfiltration
- Concrete: extensive hairline cracks, some with minor delaminations; scaling less than 0.25 in. deep or small spalls present on invert or bottom of top slab
- Footings: minor scour near footings
- 5 Generally fair condition
- Alignment: generally fair; minor misalignment or settlement; possible piping
- Joints: open and allowing backfill to infiltrate; significant cracking or spalling at joints
- Concrete: cracking open greater than 0.12 in.; significant delamination and moderate spalling exposing reinforcing steel; large areas of surface scaling greater than 0.25 in. deep
- Footings: moderate scour along footing; protective measures may be required

4 Marginal condition

Alignment: marginal; significant settlement and misalignment; evidence of piping

Joints: differential movement and separation of joints, significant infiltration or exfiltration at joints

Concrete: extensive cracking with cracks open more than 0.12 in. with efflorescence; spalling has caused exposure of rebars which are heavily corroded; extensive surface scaling on invert greater than 0.5 in.

Footings: scour along footing with slight undermining, protection required

3 Poor condition

Alignment: poor with significant ponding of water due to sagging or misalignment of pipes; end section drop off has occurred

Joints: significant openings and differential amount; infiltration or exfiltration causing misalignment of culvert and settlement or depressions in roadway

Concrete: extensive cracking with spalling, delaminations, and slight differential movement; scaling has exposed reinforcing steel in bottom to top slab or invert

Footings: severe undermining with slight differential settlement causing minor cracking or spalling in footing and walls

2 Critical condition

Alignment: critical; culvert not functioning due to severe misalignment

Concrete: severe cracks with significant differential movement; concrete completely deteriorated in isolated locations in top slab or invert

Footings: severe undermining with significant differential settlement causing severe cracks

1 Critical condition

Culvert: partially collapsed

Road: closed to traffic

Footings: severe undermining resulting in partial collapse of structure

0 Critical condition

Culvert: total failure of culvert and fill

Road: closed to traffic

Stone Culverts

Code **Condition**

9 New condition

8 Good condition

Alignment: good, no settlement or misalignment

Mortar: tight with no defects apparent

Masonry: no cracking, no missing dislocated masonry present; surface in good condition

Footings: good with no invert scour

7 Generally good condition

Alignment: generally good; minor misalignment at joints; no settlement

Mortar: shallow mortar deterioration at isolated locations

Masonry: surface deterioration at isolated locations

Footings: good with only minor invert scour

6 Fair condition

Alignment: fair, minor misalignment or settlement

Mortar: extensive areas of shallow deterioration; missing mortar at isolated locations; possible infiltration or exfiltration; minor cracking

Masonry: minor cracking of masonry units

Footings: minor scour near footings

5 Generally fair condition

- Alignment: generally fair; minor misalignment or settlement
- Mortar: mortar generally deteriorated, loose or missing mortar at isolated locations, infiltration staining apparent
- Masonry: minor cracking; slight dislocation of masonry units; large areas of surface scaling
- Footings: moderate scour along footing; protective measures may be required
- 4 Marginal condition
- Alignment: marginal; significant settlement and misalignment
- Mortar: mortar severely deteriorated, significant loss of mortar, significant infiltration or exfiltration between masonry units
- Masonry: significant displacement of individual masonry units
- Footings: scour along footing with slight undermining, protection required
- 3 Poor condition
- Alignment: poor with significant ponding of water due to sagging or misaligned pipes; end section drop off has occurred
- Mortar: extensive areas of missing mortar; infiltration or exfiltration causing misalignment of culvert and settlement or depressions in roadway
- Masonry: individual masonry units in lower part of structure missing, or crushed
- Footings: severe undermining with slight differential settlement causing minor cracking or spalling of footing and minor distress in walls
- 2 Critical condition
- Alignment: critical; culvert not functioning due to severe misalignment
- Masonry: individual masonry units in top of culvert missing or crushed
- Footings: severe undermining with significant differential settlement causing severe cracks in footing and distress in walls
- 1 Critical condition
- Culvert: partially collapsed
- Road: closed to traffic

Footings: severe undermining resulting in partial collapse of structure

0 Critical condition

Culvert: total failure of culvert and fill

Road: closed to traffic

CHANNEL

This item describes the physical conditions associated with the flow of water through the bridge such as stream stability and the condition of the channel, riprap, and slope protection. Be particularly concerned with visible signs of excessive water velocity which may affect undermining of slope protection or footings, erosion of banks, and realignment of the stream which may result in immediate or potential problems. Accumulation of drift and debris on the superstructure and substructure should be noted on the inspection form and included in the condition rating.

Item 51. Alignment

The channel should align with and cause the stream to flow under the center of the structure. The channel banks should be parallel with the substructure, such as piers and abutments.

1. Channel has straight alignment for more than 100 feet upstream.
2. Flows thru 1 out of 2 pipes; Flows along one abut. Doesn't flow under center of the bridge; minor curve (20°-40° angle); Splits into 2 or more small channels; Flows diagonally under the bridge.
3. Flows into abutment causing erosion (50°-70° angle); No flow in center span.
4. 80°-90° turn at the bridge; Erosion behind wingwall caused by channel flow.

Item 52. Protection

The method, if any, used to protect the bridge and the upstream channel banks from scour and other degradation caused by the stream action. Note and rate the condition of all channel protection and spur dikes. Vegetation is a form of channel protection.

1. No noteworthy deficiencies which affect the condition of the channel protection 100 feet upstream.

2. Bank is beginning to slump; There is minor stream bed movement evident. Several groundhog holes; most of stone has washed away; Minor erosion. Broken up concrete channel protection at inlet of a culvert.
3. Channel protection is severely undermined; Stone is completely washed away; Major erosion; Failed concrete channel protection at inlet of a culvert.
4. Channel protection has failed; channel has moved to where the bridge and approach roadway are threatened.

Item 53. Waterway Adequacy

Scour and stream bed degradation are actually the result of inadequate waterway areas. The geometry of the channel, the amount of debris carried during high water periods, and the adequacy of freeboard should be considered in determining waterway adequacy. Where large quantities of debris and ice are expected, sufficient freeboard is of the greatest importance. Check for scour of stream beds and banks, sandbars or debris which could change the direction of flow, or other obstructions which could influence the adequacy of the waterway. Accumulation of drift and debris on the superstructure and substructure should be noted on the inspection form and included in the condition rating.

Condition Codes

Bridges:

1. No restriction of flow thru the channel.
2. Silt and Gravel buildup causing flow thru one of 2 pipes; Silt and Gravel buildup restricts half of the channel; Tree or bush growing in the channel; Cattle fence attached to bridge; Rock dam under bridge.
3. Occasional over topping of bridge deck and roadway approaches with significant traffic delays; Debris caught in cross frames.
4. Frequent overtopping of bridge deck and roadway approaches with significant traffic delays.

Culverts:

1. Culvert waterway blockage is less than or equal to 5% of the cross sectional area.
2. Culvert waterway blockage is greater than 5% and less than or equal to 40%.

3. Culvert waterway blockage is greater than 40% and less than or equal to 80%.
4. Culvert waterway blockage is greater than 80%.

Item 54. Channel Summary

The following descriptive codes will be used as a guide in evaluating the condition of the channel and channel protection.

Code	Description
9	There are no noticeable or noteworthy deficiencies which affect the condition of the channel.
8	Banks are protected or well vegetated. River control devices such as spur dikes and embankment protection are not required or are in a stable condition .
7	Bank protection is in need of minor repairs. River control devices and embankment protection have minor damage. Banks and/or channel have minor amounts of drift.
6	Bank is beginning to slump. River control devices and embankment protection have widespread minor damage. There is minor stream bed movement evident. Debris is restricting the waterway slightly.
5	Bank protection is being eroded. River control devices and/or embankment have major damage. Trees and brush restrict the channel.
4	Bank and embankment protection is severely undermined. River control devices have severe damage. Large deposits of debris are in the waterway.
3	Bank protection has failed. River control devices have been destroyed. Stream bed degradation or lateral movement has changed the waterway to now threaten the bridge and/or approach roadway.
2	The waterway has changed to the extent the bridge is near a state of collapse.
1	Bridge closed because of channel failure. Corrective action may put back in light service.
0	Bridge closed because of channel failure. Replacement necessary.

Channels should be examined to determine whether any condition exists that could in any way cause damage to the bridge, embankment or other areas surrounding the bridge. Note the alignment, protection and adequacy of all waterways.

APPROACHES

A smooth transition between the roadway pavement and the bridge deck is important for the reduction of impact forces acting upon the bridge and for driving safety. A difference in elevation between the bridge deck and the approach pavement increases impact and vibration as the vehicle reaches the bridge. Rough approaches will also cause vibration in the vehicle, which in turn, transmits added vibration to the bridge.

Item 55. Pavement

Note and rate the condition of the approach pavement.

Item 56. Approach Slabs

Note and rate the condition, settlement or other signs of failure of the approach slab.

1. Approach slabs in excellent conditions, no repairs necessary.
2. Slabs may be cracked, minor spalls, but not settled.
3. Some settlement of the approach slab ends (no more than 1"); still flush with top of backwall.
4. Major settlement of approach slab ends (more than 1") or pulled away from backwall and dropped down more than 1".

Item 57. Guardrail

Note the condition of the approach guardrail. Check for integrity of posts and condition of the rail panels. The evaluated portion of the guardrail shall be limited to 100 feet from any end of the bridge.

1. No noteworthy deficiencies which affect the condition of the guardrail.
2. Minor collision damage; minor decay of posts; Guardrail is noticeably higher or lower than the standard 27 inches; Guardrail panels are very rusty; Several blockouts are missing.
3. Major collision damage; 50% loss of section of posts due to decay; Several guardrail panels are not attached to posts; Poor attachment to the end of the bridge causing a snag point; Poor installation of guardrail end assembly.
4. Guardrail is no longer functioning; Major decay of post (90%)

Item 58. Relief Joints

Relief joints are transverse openings in concrete pavements which are filled with asphalt concrete or other compressible material. These joints are placed in the vicinity of bridges to help alleviate the pressure on backwalls caused by pavement expansion in the summer months. Determine the presence of and rate the condition of these joints.

Item 59. Embankment

Note the general condition of the approach embankment for indications of settlement, bulging, stream scour and saturation from entrapped water. The evaluated portion of the embankment shall be limited to 100 feet from any end of the bridge.

1. No noteworthy deficiencies which affect the condition of the embankment.
2. Minor erosion caused by drainage; Several groundhog holes.
3. Major erosion caused by drainage or channel; Evidence of foundation settlement; Loss of edge of pavement due to poor compaction of embankment.
4. A lane of traffic is closed due to embankment failure; Several guardrail posts are hanging due to major channel erosion.

Item 60. Approaches Summary

The condition of the approaches will be summarized by the Inspector or the reviewer.

Code	Description
9	No noticeable defects
8	Hairline cracks in pavement. Minor scaling.
7	Minor problems. Very small potholes, no settlement.
6	Minor pavement deterioration, minor potholes, cracking or minor settlement

- 5 Minor cracking, spalling. Moderate potholes, cracking, with settlement and misalignment.
- 4 Broken pavement with settlement and misalignment.
- 3 Major potholes and settlement. Repairs required immediately.
- 2 Significant pavement settlement/cracking. Embankment washed out next to pavement.
- 1 Road Closed. Impending pavement and/or embankment failure
- 0 Road closed. Embankment and/or pavement failed, impassable.

GENERAL

Items in this section are of a general nature and do not relate to specific bridge elements.

Item 61. Navigation Lights

Determine whether all required navigation lights are operating and properly located. Examine the lighting fixtures for condition, visibility, electrical connections and security of attachment to insure uninterrupted service.

- 1 All lights operating, no repairs necessary to system
- 2 All lights operating, however, mounting brackets may need attention or wiring conduit may be partially disconnected
- 3 All lights operating, however lenses may be broken
- 4 Some lights burnt out or wiring circuitry non-functioning or both

Item 62. Warning Signs

All signs which advise the traveling public of restricted load limits, restricted width, restricted vertical clearance and reduced speed limits are to be inspected for legibility and condition, including any advance warning signs. Notations should be made on back side of BR-86 as to required signs which are missing or are in need of replacement due to damage or weathering .

- 1 All signs proper and legible.
- 2 Signs faded, bent, minor damage
- 3 Signs barely legible due to vandalism or fading
- 4 Signs missing or not legible

Item 63. Sign Supports

All bridge mounted traffic sign supports will be inspected for deterioration and security of connection.

The sign inspections will be primarily visual in NDT being required only if a defect is first noted visually. The inspections should concentrate primarily on the sign support anchor bolts. The attachments for signs attached to the outside of parapets should also be inspected for integrity including vibration, cracks, loose nuts or missing nuts. Attachments or connections not easily accessible within "arm's reach" should be "eyeballed" or inspected with binoculars from the bridge deck. It is not expected that the Inspector climb the sign supports to perform the inspection. Any defects noted as a result of the above-noted actions should be immediately reported to the Traffic Department so that a more In-Depth inspection can be performed by appropriate personnel with the use of their bucket truck.

Item 64. Utilities

All bridge mounted utility supports for gas, electric, water, telephone, lighting, etc. will be inspected for deterioration and security of connection. Additionally, the utilities themselves should be inspected for deterioration, loose connections, bare wires, etc. Any defects noted should be reported to the appropriate utility owner. The Inspector should compare the utilities on the bridge with the pre-printed inventory information and if changes are necessary, the inventory should be changed after returning to the office.

Item 65. Vertical Clearance

Indicate if a vertical clearance restriction exists for vehicular traffic which passes either on or below the bridge using the following codes:

- 1 A restriction exists above or below the bridge. (25' or less)
- 2 The restriction changed since the last inspection. (Due to changed conditions such as resurfacing).
- N Does not apply to this bridge.

A check should also be made to determine if the necessary signing is in place for structures with 13'-6" vertical clearance or less

Item 66. General Appraisal and Operational Status

This is a two part item. The first box is for coding the general, overall condition of the bridge. The second box is for coding the operational status of the bridge. The general appraisal will be based on the existing condition of the bridge as compared to its as-built condition. The load carrying capacity will not be used in evaluating condition items. The fact a bridge was designed for less than current legal loads and may be posted, will have no influence upon condition ratings.

The determination of which code applies to each of the items will be based on evaluation of all relevant factors and information. When rating an item, it is not necessary that all listed conditions be met to arrive at a numerical rating. It is recognized that there are unique situations where judgment will be required.

Portions of bridges that are being supported or strengthened by temporary members will be rated based on their actual condition, i.e. the temporary members are not considered in the rating of the item.

This rating is the lowest rating of either the Superstructure Summary (Item 32), or the Substructure Summary (Item 42).

A bridge with more than 3 steel plates covering large full depth holes in a deck would be a rare example where the deck summary could influence the general appraisal.

Code	Description
9	As built condition
8	Very good condition - no problems noted.
7	Good condition - some minor problems.
6	Satisfactory condition - structural elements show some minor deterioration
5	Fair condition - all primary structural elements are sound, but may have minor section loss, cracking, or spalling. Secondary elements may have significant deterioration.
4	Poor condition - advanced section loss, deterioration, or spalling.
3	Serious condition - loss of section, deterioration, or spalling have seriously affected primary structural components. Local failures or cracks in concrete or both may be present.
2	Critical condition - advanced deterioration of primary structural elements. Fatigue cracks in steel or shear cracks in concrete may be present. Bridge should be closed or closely monitored, until corrective action is taken.
1	"Imminent" failure condition - major deterioration or section loss present structural components. Bridge is closed to traffic but corrective action may put back in light service.
0	Failed condition - out of service - beyond corrective action.

The operational status of the bridge should be coded using the following:

"A"	Open, no restriction
"B"	Open, posting recommended but not legally implemented (all signs not in place)
"C"	Under construction, half of the existing bridge is open to traffic (half-width construction)
"D"	Open, would be posted or closed except for temporary shoring, etc. to allow for unrestricted traffic

- "E" Open, temporary structure in place to carry legal loads while original structure is closed and awaiting replacement or rehabilitation.
- "G" New structure not yet open to traffic
- "K" Bridge closed to all traffic
- "P" Posted for load-carrying capacity restriction (may include other restrictions)
- "R" Posted for other than load-carrying capacity restriction (speed, number of vehicles on bridge, etc.).
- "X" Bridge closed for reasons other than condition or load-carrying capacity.

Item 67. Inspected By

The inspector is to sign the inspection report and code the date of the inspection along with first, middle and last initials in the appropriate boxes. The Inspector will also type or print their name directly under the signature. Beneath the signature line are six boxes, if the inspector is a registered professional engineer, the inspector shall print their P.E. number in the spaces provided.

Item 68. Reviewed By

The reviewer of the report is to sign the report and code the date along with his first, middle, and last initials in the appropriate boxes. **A reviewer's signature is not required if the inspector is a registered professional engineer. A reviewer must be a professional engineer registered in the State of Ohio.** The signature is followed by a "P E" in the two boxes. Beneath the signature line are six boxes. The reviewer shall print their P.E. number in the spaces provided. In cases where the inspection is performed by a consultant, print the firms name below the P.E. number box. The reviewed date must always be after the inspected date.

Item 69. Survey

These eight boxes are currently being used to gather data which relates to the traffic safety features of the bridge. All eight boxes must be filled in for this survey to be valid.

The codes to be used are:

Code Meaning

- 0 Inspected feature does not meet currently acceptable standards.* Code "O" for a condition where guardrail is required and none is provided.
- 1 Inspected feature meets currently acceptable standards.*

N Not applicable.

*Until a national set of standards is approved, it will be the responsibility of the inspecting authority to determine what are acceptable standards and what are not.

Box No. Meaning

- (1) Bridge railings: Some factors that affect the proper functioning of bridge railing are height, material, strength, and geometric features. Railings must be capable of smoothly redirecting an impacting vehicle. Bridge railings should be evaluated using the AASHTO "Standard Specifications for Highway Bridges" as a guide for establishing a currently acceptable standard. Bridge on the national Highway system should be crash tested per FHWA policy and meet NCHRP 350 acceptance criteria.

Bridge railings which are typically considered to be acceptable on Ohio bridges are:

-Reinforced concrete defluctive parapet as per Standard Drawing BR-1.

-Deep beam guardrail with steel tubular backup mounted on W6 x 25 steel posts as per Standard Drawing DBR-2-73.

-Double aluminum tubes/posts mounted on concrete parapets on bridges with sidewalks inside municipalities on streets with curbs and gutters, as per Standard Drawing BR-2-82. NOTE: Railing consisting of concrete safety curbs and parapets topped with aluminum railing (Standard Drawing AR-1-57) are considered

acceptable. Some large trusses as well as culvert type bridges, have been retrofitted with singular or multiple steel tubes which were specifically designed for the particular application and as such are considered to be acceptable.

- (2) Transitions: The transition from approach rail to bridge railing requires that the approach rail be firmly attached to the bridge railing. It also requires that the approach railing be gradually stiffened as it comes close to the bridge railing. The ends of curbs and safety walks need to be gradually tapered out or shielded.

Transitions which are typically considered to be acceptable on Ohio bridges are:

-A nested thrie beam rigidly fastened to a thickened defluctive parapet as detailed on Standard Drawing GR 3.1 is the current standard.

-Bridge terminal assembly consisting of Type 5 guardrail rigidly attached to concrete defluctive parapet (unthickened) with lower section of rub rail as per Standard Drawing GR-3 has been superseded by GR 3.1, but still is considered to be acceptable for existing bridges.

-Bridge terminal assemblies as detailed on Standard Drawing GR-3A and GR-3B are still considered to be acceptable on existing bridges.

-For bridges with deep beam guardrail across the bridge, Standard Drawings GR-3, GR-3.3 and GR-3.4 depict acceptable transitions.

-Other transitions may be acceptable providing they fulfill the requirements noted in paragraph (2).

- (3) Approach guardrail: The structural adequacy and compatibility of approach guardrail with transition designs should be determined. A barrier stop at the end of a bridge is rarely needed. Thus an approach guardrail with adequate length and structural qualities to shield motorists from the hazards at a bridge site needs to be installed. In addition to being capable of safely redirecting an impacting vehicle, the approach rail must also facilitate a transition to the bridge railing that will not cause snagging or pocketing of an impacted vehicle. Acceptable guardrail design suggestions are contained in the AASHTO Guide for Selecting, Locating, and Designing Traffic Barriers.

Typical acceptable guardrails are:

-Type 5 guardrail consisting of deep beam guardrail blocked out and mounted on posts at 6' 3" centers. (See Standard Drawing GR-2.1).

-Deep beam guardrail with no blockouts mounted on posts at 12'-6" centers (see Standard Drawings GR-2C, GR-2A, GR-2.3) for roads where traffic counts less than 400 VPD.

-Wire rope and steel ribbon rail are not considered acceptable as guardrail approaching bridges.

- (4) Approach rail ends: As with guardrail ends in general, the ends of approach rails to bridges should be flared, buried, made breakaway, or shielded. Design treatment of guardrail ends is given in the AASHTO Guide for Selecting, Locating, and Designing Traffic Barriers.
- (5) Pavement Marking: At or on the structure - centerline or lane lines, edge lines for structure with berm. See Ohio Manual of Uniform Traffic Control Devices (OMUTCD).
- (6) Restriction Signing: Regulatory signing such as load limit or spacing. See OMUTCD
- (7) Warning Signing: Narrow bridge. One lane, Vertical Clearance. See OMUTCD
- (8) Bridge End Markers: Delineation at ends of structure for narrow structures. See OMUTCD

The data collected will apply only to the route on the bridge. Collision damage or deterioration of the elements are not considered when coding this item.

SUSPENSION BRIDGES

If inspecting a suspension or moveable bridge, two forms must be used. The applicable Items on the standard BR-86 form are to be filled out as well as the supplemental form. For copies of the supplemental form, please contact the District Bridge Engineer.

Item 68. Main Cables

The large cables or eyebar chains which are draped over the towers and bent posts and from which the superstructure is suspended form make up the main cables. Check these cables for evidence of broken

wires and leakage from within. Occasionally (once every 10 years) portions of the main cables should be unwrapped and checked for the above noted deficiencies as well as general condition (paint, rust, etc.).

Item 69. Suspenders

The generally vertical wire cables, metal rods or bars designed to engage a cable band or other device connecting them to the main suspension cable at one end and to the suspended superstructure at the other end, thus permitting them to assist in supporting the bridge floor system and its superimposed loads by transferring loads to the main suspension members of the structure.

A member serving to support another member in a vertical or an inclined position against sagging, twisting, or other deformation due to its own weight.

Check for worn or broken wires and relative tension in adjacent suspenders.

Item 70. Cable Bands

The clamps around the main cables over which the suspenders are looped. Check for missing bolts, looseness of band, evidence of downhill slippage, lack of caulking between bands and main cables, and rotation of band on the main cable.

Item 71. Suspender Connections

The suspender ends or sockets which are attached to the superstructure. Look for evidence of disintegrated or frayed wires at the sockets. Also check the integrity of the bracket which is attached to the superstructure.

Be particularly cognizant of debris and rust-through of any connections in the splash zone.

Item 72. Towers

A large pier or frame extending well above the roadway and serving to support the cables or chains of a suspension type bridge at the ends of the main span.

Check the base connections for integrity. Carefully check all areas subject to drainage and splash.

Item 73. Tower Saddles

The saddles at the top of the towers in which the main cables rest. Check for evidence of movement of the main cable within the saddle and proper caulking.

Item 74. Bent Posts

The shorter towers at the ends of the bridge which support the main cable or chain. Generally, the cable or chain is nearly horizontal at this point and then abruptly changes direction and goes immediately down to the anchorages.

Check for evidence of movement, deterioration in the splash zone, and integrity of the base connections.

Item 75. Anchorage

The point at which the cable or chain terminates in the foundation. Check for broken and rusted wires where they are splayed and looped around pins and eyebars. Also check eyebars for section loss where they are embedded in the concrete. Check for unusual dampness or standing water.

Item 77. Summary

See General Appraisal Codes

MOVABLE BRIDGES**Items 78. - 99.**

Refer to "Bridge Inspector's Manual For Movable Bridges", 1977, U.S. Department Of Transportation, Federal Highway Administration, for descriptions.

Item 78. Gears - Check for misalignment; tooth wear; evidence of lubrication.

Item 79. Shafts - Check for wear; vibration; cracks.

Item 80. Bearings - Check for evidence of wear; vibration; adequate lubrication.

Item 81. Electric Motors - Make continuity/resistance tests.

Item 82. Auxiliary Engines - Check for ease of starting; lubrication.

Item 83. Center Locks - Check for proper engagement, lubrication, wear, cracks.

Item 84. Tail Locks - Check for proper engagement, lubrication, wear, cracks.

Item 85. Reducers - Check for lubrication, gear alignment, tooth wear.

Item 86. Couplings - Check for tightness.

Item 87. Wire Ropes - Check for broken or frayed ropes.

Item 88. Sockets - Check for evidence of slippage; corrosion of wire rope where it enters socket.

Item 89. Span Balance - Check for smoothness of operation, excessive impact upon closure.

Item 90. Buffers - Check for proper operation, excessive wear, fluid leakage.

Item 91. Brakes - Check for wear.

Item 92. Transformers - Check for leakage; make appropriate electrical tests.

Item 93. Circuit Breakers - Test for proper operation.

Item 94. Limit Switches - Test for proper operation.

Item 95. Traffic Gates/Lights - Check operation, visibility, damage, wear.

Item 96. Lubrication - Check for evidence of proper lubrication, presence of dirt in grease.

Item 97. General Operation - Check for smoothness of operation, housekeeping.

Item 99. Summary

MISCELLANEOUS ADDITIONAL INFORMATION FOR CODING THE BR-86 FORM

Do not enter more than one character in any coding box. The condition code should be selected which indicates the "most representative" or "least adequate" condition. See individual item descriptions for specific instructions. The "X" code is not allowed in any condition box. Send in original reports only. The copies should be kept in the District file or the County office. Always use the preprinted forms, not hand written ones, to assure accuracy of the bridge information year after year. The only exceptions for using blank

BR-86's are

- 1) Newly inventoried bridges (inspections which are submitted at the same time as the corresponding BR-87 or bridges which were filed after the time of printing of the preprinted BR-86 Forms).
- 2) Critical condition bridges which need to be inspected more than once a year.

If a pre-printed BR-86 is received for a bridge that has been replaced, destroy the pre-printed BR-86 and fill out a blank BR-86. In this instance, the old bridge must have already been retired and a new BR-87 submitted for the new bridge, as described in the Bridge Inventory and Appraisal Coding Guide.

An inventory sheet (BR-87) must always be on file for a particular bridge before the corresponding inspection report BR-86 can be accepted.

For non-culvert type bridges, all applicable Summary Items must be filled in (except Item 50) in order to generate a sufficiency rating for the bridge.

For culvert type bridges, only Summary Items 50, 54, 60 and 64 must be filled in to obtain a sufficiency rating.

APPENDIX ITEMS

- Bridge Ownership Matrix
- Scour Plan of Action
- Critical Findings Report
- Alternate Entry Form
- QAR form
- Bridge inspection report – Form BR-86
- Bridge inspection report – Form BR-86

OUTSIDE MUNICIPAL LIMITS

Route Type		Jurisdictional Ownership	Inspection Responsibility	Maintenance Responsibility	
On Bridge	Under Bridge			Primary	Secondary
Interstate	Interstate	State	State	State	State
Interstate	State (US) Route w/LA	State	State	State	State
Interstate	State (US) Route	State	State	State	State
Interstate	County	State	State	State	State
Interstate	Township	State	State	State	State
Interstate	Railroad	State	State	State	State
Interstate	abandoned RR/Private Road	State	State	State	State
Interstate	Water/ditch/intermittent stream	State	State	State	State
Interstate	Other (utility, Pedestrian, building)	State	State	State	State
State (US) Route w/LA	Interstate	State	State	State	State
State (US) Route w/LA	State (US) Route w/LA	State	State	State	State
State (US) Route w/LA	State (US) Route	State	State	State	State
State (US) Route w/LA	County	State	State	State	State
State (US) Route w/LA	Township	State	State	State	State
State (US) Route w/LA	Railroad	State	State	State	State
State (US) Route w/LA	abandoned RR/Private Road	State	State	State	State
State (US) Route w/LA	Water/ditch/intermittent stream	State	State	State	State
State (US) Route w/LA	Other (utility, Pedestrian, building)	State	State	State	State
State (US) Route	Interstate	State	State	State	State
State (US) Route	State (US) Route w/LA	State	State	State	State
State (US) Route	State (US) Route	State	State	State	State
State (US) Route	County	State	State	State	State
State (US) Route	Township	State	State	State	State
State (US) Route	Railroad	State	State	State	State
State (US) Route	abandoned RR/Private Road	State	State	State	State
State (US) Route	Water/ditch/intermittent stream	State	State	State	State
State (US) Route	Other (utility, Pedestrian, building)	State	State	State	State
County	Interstate	State	State	State	County
County	State (US) Route w/LA	State	State	State	County
County	State (US) Route	County	County	County	County
Township	Interstate	State	State	State	County
Township	State (US) Route w/LA	State	State	State	County
Township	State (US) Route	County	County	County	County
Railroad	Interstate	Railroad *	Railroad *	Railroad *	Railroad *
Railroad	State (US) Route w/LA	Railroad	Railroad	Railroad	Railroad
Railroad	State (US) Route	Railroad	Railroad	Railroad	Railroad
Other (utility, Pedestrian, build	Interstate	Other	State	Other	Other
Other (utility, Pedestrian, build	State (US) Route w/LA	Other	State	Other	Other
Other (utility, Pedestrian, build	State (US) Route	Other	State	Other	Other
					157
abandoned RR	State Route	State	State	N/A	N/A

INSIDE MUNICIPAL LIMITS							
On Bridge	Route Type		Jurisdictional Ownership	Inspection Responsibility	Maintenance Responsibility		REF.
		Under Bridge			Primary	Secondary	
Village	Interstate		City/Village	State**	State^	City/Village	
Village	State (US) Route w/LA		City/Village	State**	County	City/Village	
Village	State (US) Route		City/Village	State**	village	City/Village	
Railroad	Interstate		Railroad	State**	Railroad	Railroad	
Railroad	State (US) Route w/LA		Railroad	State**	Railroad	Railroad	
Railroad	State (US) Route		Railroad	State**	Railroad	Railroad	
Other (utility, Pedestrian,	Interstate		Other/city	State**	Other/city	Other/city	
Other (utility, Pedestrian,	State (US) Route w/LA		Other/city	State**	Other/city	Other/city	
Other (utility, Pedestrian,	State (US) Route		Other/city	State**	Other/city	Other/city	

** RC 5501.47 requires the Director to inspect all bridges on the state highway system inside and outside of municipalities.

^ RC 5591.21 states that "the board of county commissioners shall construct and keep in repair necessary bridges over streams and public canals on or connecting state, county, and improved roads." RC 5591.02 states that county commissioners shall construct and keep in repair all bridges on all state and county roads and improved roads which are of general and public utility, running into or through a municipal corporation.

See Urban Paving Policy: "ODOT has and will continue to participate in the re-decking and reconstruction of all bridges on state and U.S. routes in municipalities at 100 percent. As with freeways, ODOT will repair these bridges as warranted compared to all other district bridge conditions. **Local government has been and still will be responsible for routine maintenance.**"

^ A agreement may exist. See contract form MR 679

* RC 5523.20 Bridge could have been constructed as part of a grade separation project, requires the Director to maintain the bridges.

State Highways Bridges (within Corporation Limits) see ORC 5591.02 and OAG 74-007
 State Highways Bridges (outside of Corporation Limits) see ORC 5511.01 and ORC 5535.01

Lift Bridges see ORC 5501.49 and ORC5591.02

City Street Bridges see ORC 723.01
 City Street Bridges crossing a stream or canal see ORC 5591.21
 Village Street Bridges (with or without stream or canal crossing) see ORC 5591.02 and ORC 9991.21
 Township Road Bridges see ORC 5591.21 and ORC 5535.01

3. SCOUR COUNTERMEASURE RECOMMENDATION																									
Completed Countermeasures:																									
Proposed Countermeasures:																									
<p><input type="checkbox"/> Countermeasures Not Required. (Please explain)</p> <p><input type="checkbox"/> Install Scour Countermeasures (See 4 and 5)</p> <table style="width: 100%; border: none;"> <thead> <tr> <th style="width: 80%;"></th> <th style="text-align: right; border-bottom: 1px solid black;"><u>Estimated Cost</u></th> </tr> </thead> <tbody> <tr> <td style="padding-left: 20px;">___ Riprap with monitoring program</td> <td style="text-align: right;">\$</td> </tr> <tr> <td style="padding-left: 20px;">___ Guide bank</td> <td style="text-align: right;">\$</td> </tr> <tr> <td style="padding-left: 20px;">___ Spurs</td> <td style="text-align: right;">\$</td> </tr> <tr> <td style="padding-left: 20px;">___ Relief bridge / Culvert</td> <td style="text-align: right;">\$</td> </tr> <tr> <td style="padding-left: 20px;">___ Channel improvements</td> <td style="text-align: right;">\$</td> </tr> <tr> <td style="padding-left: 20px;">___ Monitoring</td> <td style="text-align: right;">\$</td> </tr> <tr> <td style="padding-left: 20px;">___ Monitoring device</td> <td style="text-align: right;">\$</td> </tr> <tr> <td style="padding-left: 20px;">___ Check Dam</td> <td style="text-align: right;">\$</td> </tr> <tr> <td style="padding-left: 20px;">___ Substructure Modification</td> <td style="text-align: right;">\$</td> </tr> <tr> <td style="padding-left: 20px;">___ Bridge replacement</td> <td style="text-align: right;">\$</td> </tr> <tr> <td style="padding-left: 20px;">___ Other _____</td> <td style="text-align: right;">\$</td> </tr> </tbody> </table>			<u>Estimated Cost</u>	___ Riprap with monitoring program	\$	___ Guide bank	\$	___ Spurs	\$	___ Relief bridge / Culvert	\$	___ Channel improvements	\$	___ Monitoring	\$	___ Monitoring device	\$	___ Check Dam	\$	___ Substructure Modification	\$	___ Bridge replacement	\$	___ Other _____	\$
	<u>Estimated Cost</u>																								
___ Riprap with monitoring program	\$																								
___ Guide bank	\$																								
___ Spurs	\$																								
___ Relief bridge / Culvert	\$																								
___ Channel improvements	\$																								
___ Monitoring	\$																								
___ Monitoring device	\$																								
___ Check Dam	\$																								
___ Substructure Modification	\$																								
___ Bridge replacement	\$																								
___ Other _____	\$																								

3. COUNTERMEASURE IMPLEMENTATION SCHEDULE	
Countermeasure Implementation Project Type:	
<input type="checkbox"/> Proposed Construction Project Lead Agency	
<input type="checkbox"/> Maintenance Project	
Sale Date:	
Other scheduling information:	

4. MONITORING PLAN**Monitoring Plan Summary:****Monitoring Authority:**

Regular Annual Inspection Program

Items to Watch:

w/surveyed cross sections

Increased Inspection Interval of _____ mo. w/surveyed cross sections

Items to Watch:

Underwater Inspection Program

Items to Watch:

Frequency _____ mo.

Fixed Monitoring Device

Type of Instrument:

Installation location(s):

Scour-critical discharge: _____

Action required if scour-critical elevation detected:

Other Monitoring Program

Type: Visual

Instrument

Portable Geophysical Sonar

Other gages

Flood monitoring required:

Yes

No

Flood monitoring event defined by:

Discharge over _____

Stage _____

Elev. measured from _____

Frequency of flood monitoring: 1 hr. 3 hr. 6 hrs. Other

Scour critical elevation:

Action required if scour-critical elevation detected:

5. BRIDGE CLOSURE PLAN**Closure Plan Summary****Scour Monitoring Criteria for Consideration of Bridge Closure:**

- | | |
|--|--|
| <input type="checkbox"/> Water surface elevation reaches _____ | <input type="checkbox"/> Overtopping road or structure |
| <input type="checkbox"/> Scour Measurement Results / Monitoring Device | <input type="checkbox"/> Loss of Riprap |
| <input type="checkbox"/> Observed amount of Settlement | <input type="checkbox"/> Loss of Road Embankment |
| <input type="checkbox"/> Debris Accumulation | |
| <input type="checkbox"/> Other _____ | |

Person / Area Responsible for Closure:**Contact People (Name & Phone No.):****Responsible for re-opening after inspection:**

6. DETOUR ROUTE

Detour route description (route number, from - to, etc.) – attach map.

Detour length

Signs required for closure:

Bridges on Detour Route:

Structural File Number	Bridge Number	Waterway	Load Rating Other restrictions

CRITICAL FINDINGS REPORT

PURPOSE: The National Bridge Inspection Standards (23 CFR 650 subpart C) states critical findings are to be documented and addressed in a timely manner. This documentation is to do be completed upon the finding of a critical bridge deficiency.	
Date:	Page of
Owner:	
Structure File Number:	
Bridge Number:	
Inspection Agency:	
Description of critical findings:	
Immediate action taken to ensure safety of traveling public	
Current plan of action for the bridge	
Pictures attached	

Quality Assurance Review Bridge Inspection Program

SCOPE OF REVIEW:

The purpose of the Quality Assurance Review Program is to evaluate program effectiveness, uniformity, and compliance with federal and state rules relating to bridge inspections. The inventory may be reviewed as a whole or in parts.

The review consisted of two parts.

Part I – An office review is an evaluation of the organization’s procedures, resources, and documentation regarding the inspection, inventory, and maintenance operations for bridges.

Part II – A field review of bridge inspection reports of bridges to determine if ratings were consistent with the ODOT Coding Manual and FHWA Recording and Coding Guide.

Agency Under Review	Date
Agency Performing Review	QAR members
Comments	

PART I - Qualifications

This section is to determine if personnel meet federal and state qualification requirements. Please refer to Section 1 of the Ohio Department of Transportation Manual of Bridge Inspection for the required qualifications. If a consultant is hired to manage the program and/or inspect bridges, it is recommended that they are present during the quality assurance review. **IMPORTANT: Attach all supporting documentation**

Inspection Program Manager - Person in charge of inspection program

Name		
Professional Engineer <input type="checkbox"/> Yes <input type="checkbox"/> No		
Date of inspection class		
Experience		
Training		
Time Allocation		
Bridge Inspection	Other Bridge Related Activities	Non-Bridge Activities
Additional Notes:		

Inspection Team Leader; 1 OF ____ - Person in charge of signing inspection form

Name		
Professional Engineer <input type="checkbox"/> Yes <input type="checkbox"/> No		
Date of inspection class		
Experience		
Training		
Time Allocation		
Bridge Inspection	Other Bridge Related Activities	Non-Bridge Activities
Additional Notes:		

Inspection Team Leader; 2 OF ____ - Person in charge of signing inspection form

Name		
Professional Engineer <input type="checkbox"/> Yes <input type="checkbox"/> No		
Date of inspection class		
Experience		
Training		
Time Allocation		
Bridge Inspection	Other Bridge Related Activities	Non-Bridge Activities
Additional Notes:		

Inspection Team Leader; 3 OF ____ - Person in charge of signing inspection form

Name		
Professional Engineer <input type="checkbox"/> Yes <input type="checkbox"/> No		
Date of inspection class		
Experience		
Training		
Time Allocation		
Bridge Inspection	Other Bridge Related Activities	Non-Bridge Activities
Additional Notes:		

Inspection Team Member; 1 OF ____ - People that assist the Team Leader with inspections. Does not sign the inspection report

Name		
Professional Engineer <input type="checkbox"/> Yes <input type="checkbox"/> No		
Date of inspection class		
Experience		
Training		
Time Allocation		
Bridge Inspection	Other Bridge Related Activities	Non-Bridge Activities
Additional Notes:		

Inspection Team Member; 2 OF ____ - People that assist the Team Leader with inspections. Does not sign the inspection report

Name		
Professional Engineer Yes No		
Date of inspection class		
Experience		
Training		
Time Allocation		
Bridge Inspection	Other Bridge Related Activities	Non-Bridge Activities
Additional Notes:		

PART I - RECORD KEEPING

Bridge owners are required to maintain a complete, accurate and current record of each bridge under their jurisdiction. Complete information, in good usable form, is vital to the effective management of bridges.

Bridge File - The bridge file describes all bridges under the jurisdiction of the Program Manager. This file should contain all cumulative information about each individual bridge.

General	
Number of Bridge	
Inspection Responsibility	Maintenance Responsibility
Record retention for inspections	
List of Bridges	
Fracture Critical Inspections	Plans with detail
Underwater Inspections	
Special Inspections	
Emergence closure procedures	
Bridges over water	
Assessed for scour susceptibility	
Scour Critical Bridges	
Plan of Action	
Load Posted Bridges	
Analyzed bridges	

PART I –Bridge Files

A sample of ____ individual bridge files were examined for completeness

Bridge file 1 of ____, Checklist of activity

YES	NO	N/A	DOCUMENT
			Correspondence
			Original inspection survey
			Bridge Plans – Original
			Bridge Plans – Rehabilitation
			Load Rating Analysis (Computation)
			Initial/Updated inventory reports
			Routine Inspection Reports
			Maintenance activities
			Scour Evaluation
			Plan of Action for Scour if Scour Critical
			Other
Inspection Types			
			Fracture Critical inspection and Documents
			Damage Inspections
			Underwater Inspections
			Interim Inspections
			In-Depth Inspections

ADDITIONAL COMMENTS:

PART I - INSPECTIONS

Bridge Inspections are conducted to determine the physical and functional condition of the bridge. Successful bridge inspection is dependent on proper planning and techniques, adequate equipment, and the experience and reliability of the personnel performing the inspection.

Planning and Scheduling	
Number of Bridges the program is Responsible to Inspect	
Number of Inspections Performed in the Past Calendar Year	
Number of Inspections Performed in a Day	
Length of Time for an Average Inspection	
Previous Inspection Reports Available at the Bridge for Review? <input type="checkbox"/> Yes <input type="checkbox"/> No	Bridge Plans Taken to the Bridge for use During Inspection ? <input type="checkbox"/> Yes <input type="checkbox"/> No
Bridge Plans Available in Office, if needed	<input type="checkbox"/> Yes <input type="checkbox"/> No
Comments:	

PART I - INSPECTIONS

Initial Inspections (New or Rehabilitated)	
Number of inspections performed	
Baseline Assessments preformed	Inventory Report Verified
<input type="checkbox"/> Yes <input type="checkbox"/> No	<input type="checkbox"/> Yes <input type="checkbox"/> No
Comments:	
Routine Inspections	
Number of inspections performed	
Damage Inspections	
Number of inspections performed	
In-Depth Inspections	
Number of inspections performed	
Underwater Inspections	
Number of inspections performed	
Fracture Critical Inspections	
Number of inspections performed	
Are schematics used <input type="checkbox"/> Yes <input type="checkbox"/> No	
Special Inspection	
Interim Inspections	
Types of NDT used	

PART I - INSPECTION EQUIPMENT

List equipment carried on vehicle for inspection and taken to site

Y/N/A	EQUIPMENT	Y/N/A	EQUIPMENT	Y/N/A	EQUIPMENT
	Extension Ladder				Feeler Gauge
	100-Foot Tape		Steel Wire Brush		Probing Rod
	6-Foot Rule		Brass Wire Brush		Vertical Clearance Rod
	Geologist Hammer		Calipers		Radio / Cell Phone
	Inspection Mirror		Shovel		2-inch Scraper
	Flashlight		Inspection Forms		Optical Crack Gauge
	Thermometer		Extra Paper		Magnifying Glass
	Plumb Bob/Protractor		Screwdriver		Flashing Light
	Camera		Pliers		Harness/Lanyard
	2-Foot/4-Foot Level		Wrenches		
	Binoculars		Incremental Borer		
	Brush Hook		Sounding Chains		
	Laptop Computer		Hip Boots / Waders		
	Boat		Paint Stick / Marker		
	Life Jackets		Scraper		

Y/N/A – Yes, No, Available

Personnel Safety Equipment

Inspection regularly performed by a team of two or more <input type="checkbox"/> Yes <input type="checkbox"/> No			
Y/N/A	EQUIPMENT	Y/N/A	EQUIPMENT
	<input type="checkbox"/> Hard Hat		<input type="checkbox"/> Ear Protection
	<input type="checkbox"/> Safety Vests		<input type="checkbox"/> Confined Space Air Monitor
	<input type="checkbox"/> Safety Glasses		<input type="checkbox"/> First Aid Kit
	<input type="checkbox"/> Safety Shoes		<input type="checkbox"/> Dusk Mask
	<input type="checkbox"/> Safety Harness		<input type="checkbox"/> Ear Protection
	<input type="checkbox"/> Respirator		<input type="checkbox"/> Confined Space Air Monitor

Y/N/A – Yes, No, Available

PART I - CRITICAL FINDINGS/FOLLOW UP ACTIONS

Each inspection report shall be reviewed by the maintaining authority for completeness, accuracy, and recommendations. The inspector's recommendations should be considered for implementation within the limits established for public safety, cost effectiveness, and fiscal restraints

Critical Findings
Number reports submitted to ODOT Office of Structural Engineering
Fracture Critical Member scour or hydraulic problems reduction in safe load capacity a value of 2 or less for items: Deck Summary Superstructure Summary Substructure Summary Culvert Summary

Maintenance Follow up	
Inspectors Recommend Maintenance Actions on Inspection Form <input type="checkbox"/> Yes <input type="checkbox"/> No	Recommendations are Categorized or Prioritized <input type="checkbox"/> Yes <input type="checkbox"/> No
Special Maintenance Form Used <input type="checkbox"/> Yes <input type="checkbox"/> No	
Number of maintenance contracts let last year	At a cost of
Describe Who You Contact for Bridge Projects	
Describe How Bridge Projects are Prioritized	
Describe Problems Encountered in Attempting to program a Bridge	

INSPECTED AGENCY COMMENTS

We have asked a detailed list of questions. Please take this opportunity to ask questions or make comments about the inspection program.

GENERAL

Does bridge inspection team feel it has enough time / equipment / training / experience to do their job properly?

PART II - FIELD REVIEW

The field review is intended to look at _____ bridges (typically with problems); bridges that are in the replacement program; bridges with special features; bridges of local interest or questions; and load posted bridges.

List bridges along with reasons for selection.

SUMMARY OF REVIEW COMMENTS

Reviewer's Comments

Reviewer's Confidence Level

Good

**Needs
improvement**

5

4

3

2

1

ALTERNATE ENTRY FORM

NEVER INTRODUCE ANY SOURCE OF IGNITION OR SWITCH ON ANY ELECTRICAL MOTOR OR LIGHT IN A CONFINED SPACE UNLESS YOU ARE POSITIVE THAT A FLAMMABLE ATMOSPHERE DOES NOT EXIST.

****SMOKING IS STRICTLY PROHIBITED INSIDE ANY CONFINED SPACE****

--	--	--	--	--	--	--	--	--	--

CULVERT or STRUCTURAL FILE NUMBER

DATE: _____

LOCATION: _____

ENTRANT: _____
(PRINT NAME)

PRE-ENTRY CONTACT WITH BASE:

(CONTACT NAME) (TIME)

ATMOPHERIC READINGS

GAS	LOW READING	HIGH READING	ACCEPTABLE LEVEL
Oxygen (O ₂)			19.5 % - 23.5%
Combustibles			0 - 10% LEL
Carbon Monoxide (CO)			0 - 35 PPM
Hydrogen Sulfide (H ₂ S)			0 - 10 PPM

Notes:

POST-ENTRY CONTACT WITH BASE:

(CONTACT NAME) (TIME)

ENTRANT: _____
(SIGNATURE)

STATE OF OHIO DEPARTMENT OF TRANSPORTATION BRIDGE INSPECTION REPORT					
BR-86 REV. 02-05		BRIDGE NUMBER _____		YEAR BUILT _____	
1 STRUCTURE FILE NUMBER 7		CO _____	ROUTE _____	UNIT _____	
DIST. _____		BRIDGE TYPE _____		TYPE SERVICE _____	
DECK					
1. FLOOR	8	2. WEARING SURFACE	41		
3. CURBS, SIDEWALKS & WALKWAYS	9	4. MEDIAN	42		
5. RAILING	10	6. DRAINAGE	43		
7. EXPANSION JOINTS	11	8. SUMMARY	44		
SUPERSTRUCTURE					
9. ALIGNMENT	12	10. BEAMS/GIRDERS/SLAB	45		
11. DIAPHRAGMS or CROSSFRAMES	13	12. JOISTS/STRINGERS	46		
13. FLOOR BEAMS	14	14. FLOOR BEAM CONNECTIONS	47		
15. VERTICALS	15	16. DIAGONALS	48		
17. END POSTS	16	18. TOP CHORD	49		
19. LOWER CHORD	17	20. LOWER LATERAL BRACING	50		
21. TOP LATERAL BRACING	18	22. SWAY BRACING	51		
23. PORTALS	19	24. BEARING DEVICES	52		
25. ARCH	20	26. ARCH COLUMNS or HANGERS	53		
27. SPANDREL WALLS	21	28. PROTECTIVE COATING SYSTEM (PCS)	54		
29. PINS/HANGERS/HINGES	22	30. FATIGUE PRONE CONNECTIONS	55		
31. LIVE LOAD RESPONSE	23	32. SUMMARY	56		
SUBSTRUCTURE					
33. ABUTMENTS	24	34. ABUTMENT SEATS	57		
35. PIERS	25	36. PIER SEATS	58		
37. BACKWALLS	26	38. WINGWALLS	59		
39. FENDERS and DOLPHINS	27	40. SCOUR	60		
41. SLOPE PROTECTION	28	42. SUMMARY	62		
CULVERTS					
43. GENERAL	29	44. ALIGNMENT	63		
45. SHAPE	30	46. SEAMS	64		
47. HEADWALLS or ENDWALLS	31	48. SCOUR	65		
49	32	50. SUMMARY	66		
CHANNEL					
51. ALIGNMENT	33	52. PROTECTION	67		
53. WATERWAY ADEQUACY	34	54. SUMMARY	68		
APPROACHES					
55. PAVEMENT	35	56. APPROACH SLABS	69		
57. GUARDRAIL	36	58. RELIEF JOINTS	70		
59. EMBANKMENT	37	60. SUMMARY	71		
GENERAL					
61. NAVIGATION LIGHTS	38	62. WARNING SIGNS	72		
63. SIGN SUPPORTS	39	64. UTILITIES	73		
65. VERTICAL CLEARANCE	40	66. GENERAL APPRAISAL & OPERATIONAL STATUS	74		
67. INSPECTED BY		68. REVIEWED BY		COND. STAT.	
_____ SIGNED _____		_____ SIGNED _____		_____	
76 PE NUMBER		78 INITIALS		81 PE NUMBER	
_____		_____		_____	
77 INITIALS		83 INITIALS		_____	
_____		_____		_____	
DATE _____		DATE _____		DATE _____	
86 91		89 SURVEY 99		100 105	